



SERVICE & OPERATING MANUAL

Original Instructions

Certified Quality



Model F30

Metallic
Design Level 1



FTA Pumps, Inc.
A Unit of PRG Corporation
12251 Northwoods Park Dr.
Houston, TX 77041 USA
Telephone 281.654.6499
Fax 214.432.6173
FTAPUMP.COM



© Copyright 2022 FTA Pump, Inc.
All rights reserved

1: PUMP SPECS

2: INSTAL & OP

3: EXP VIEW

4: AIR END

5: WET END

6: OPTIONAL

Safety Information

IMPORTANT



Read the safety warnings and instructions in this manual before pump installation and start-up. Failure to comply with the recommendations stated in this manual could damage the pump and void factory warranty.



When the pump is used for materials that tend to settle out or solidify, the pump should be flushed after each use to prevent damage. In freezing temperatures the pump should be completely drained between uses.

CAUTION



Before pump operation, inspect all fasteners for loosening caused by gasket creep. Retighten loose fasteners to prevent leakage. Follow recommended torques stated in this manual.



Nonmetallic pumps and plastic components are not UV stabilized. Ultraviolet radiation can damage these parts and negatively affect material properties. Do not expose to UV light for extended periods of time.



WARNING
Pump not designed, tested or certified to be powered by compressed natural gas. Powering the pump with natural gas will void the warranty.

WARNING



When used for toxic or aggressive fluids, the pump should always be flushed clean prior to disassembly.



Before maintenance or repair, shut off the compressed air line, bleed the pressure, and disconnect the air line from the pump. Be certain that approved eye protection and protective clothing are worn at all times. Failure to follow these recommendations may result in serious injury or death.



Airborne particles and loud noise hazards. Wear eye and ear protection.



In the event of diaphragm rupture, pumped material may enter the air end of the pump, and be discharged into the atmosphere. If pumping a product that is hazardous or toxic, the air exhaust must be piped to an appropriate area for safe containment.



Take action to prevent static sparking. Fire or explosion can result, especially when handling flammable liquids. The pump, piping, valves, containers and other miscellaneous equipment must be properly grounded.



This pump is pressurized internally with air pressure during operation. Make certain that all fasteners and piping connections are in good condition and are reinstalled properly during reassembly.



Use safe practices when lifting

ATEX Pumps - Conditions For Safe Use

1. Ambient temperature range is as specified in tables 1 to 3 on the next page (per Annex I of DEKRA 18ATEX0094X)
2. ATEX compliant pumps are suitable for use in explosive atmospheres when the equipment is properly grounded in accordance with local electrical codes
3. **Non-Metallic ATEX Pumps only** — See Explanation of Pump Nomenclature / ATEX Details Page
Conductive Polypropylene, conductive Acetal or conductive PVDF pumps are not to be installed in applications where the pumps may be subjected to oil, greases and hydraulic liquids.
4. The optionally provided solenoids shall be protected by a fuse corresponding to its rated current (max $3 \cdot I_{rat}$ according to EN 60127) or by a motor protecting switch with short circuit and thermal instantaneous tripping (set to the rated current) as short circuit protection. For solenoids with a very low rated current, a fuse with the lowest current value according to the indicated standard will be sufficient. The fuse may be accommodated in the associated supply unit or shall be separately arranged. The rated voltage of the fuse shall be equal or greater than the stated rated voltage of the solenoid. The breaking capacity of the fuse shall be as high as or higher than the maximum expected short circuit current at the location of the installation (usually 1500 A). The maximum permissible ripple is 20% for all dc solenoids.
***Not applicable for all pump models — See Explanation of Pump Nomenclature / ATEX Details Page**
5. When operating pumps equipped with non-conductive diaphragms that exceed the maximum permissible projected area, as defined in EN ISO 80079-36 : 2016 section 6.7.5 table 8, the following protection methods must be applied
 - Equipment is always used to transfer electrically conductive fluids or
 - Explosive environment is prevented from entering the internal portions of the pump, i.e. dry running.
6. Pumps provided with the pulse output kit and used in the potentially explosive atmosphere caused by the presence of the combustible dust shall be installed in such a way that the pulse output kit is protected against impact
***Not applicable for all pump models — See Explanation of Pump Nomenclature / ATEX Details Page**

Temperature Tables

Table 1. Category 1 & Category 2 ATEX Rated Pumps

Ambient Temperature Range [°C]	Process Temperature Range [°C] ¹	Temperature Class	Maximum Surface Temperature [°C]
-20°C to +60°C	-20°C to +80°C	T5	T100°C
	-20°C to +108°C	T4	T135°C
	-20°C to + 160°C	T3	T200°C
	-20°C to +177°C	(225°C) T2	

¹Per CSA standards ANSI LC6-2018 US & Canadian Technical Letter R14, G-Series Natural Gas Models are restricted to (-20°C to + 80°C) process temperature

Table 2. Category 2 ATEX Rated Pumps Equipped with Pulse Output Kit or Integral Solenoid:

Ambient Temperature Range [°C]	Process Temperature Range [°C]	Temperature Class	Maximum Surface Temperature [°C]	Options	
				Pulse Output Kit	Integral Solenoid
-20°C to +60°C	-20°C to +100°C	T5	T100	X	
-20°C to +50°C	-20°C to +100°C	T5	T100		X

²ATEX Pulse output or Intergral Solenoid Not Available For All Pump Models See Explanation of Pump Nomenclature / ATEX Details Page

Table 3. Category M1 ATEX Rated Pumps for Mining

Ambient Temperature Range [°C]	Process Temperature Range [°C]
-20°C to +60°C	-20°C to +150°C

Note: The ambient temperature range and the process temperature range should not exceed the operating temperature range of the applied non-metallic parts as listed in the manuals of the pumps.

Table of Contents

1: PUMP SPECS

SECTION 1: PUMP SPECIFICATIONS.....1

- Explanation of Nomenclature
- Performance
- Materials
- Dimensional Drawings

2: INSTAL & OP

SECTION 2: INSTALLATION & OPERATION ...4

- Principle of Pump Operation
- Recommended Installation Guide
- Troubleshooting Guide

3: EXP VIEW

SECTION 3: EXPLODED VIEW.....7

- Composite Repair Parts Drawing
- Composite Repair Parts List
- Material Codes

4: AIR END

SECTION 4: AIR END10

- Air Distribution Valve Assembly
- Air Valve with Stroke Indicator Assembly
- Pilot Valve Assembly
- Intermediate Assembly

5: WET END

SECTION 5: WET END.....16

- Diaphragm Drawings
- Diaphragm Servicing

6: OPTIONAL

SECTION 6: OPTIONAL CONFIGURATIONS .18

- Solenoid Shifted Air Valve
- Dual Port
- Electronic Leak Detector Installation Instructions

SECTION 7: WARRANTY & CERTIFICATES ..21

- Warranty
- CE Declaration of Conformity - Machinery
- ATEX Declaration of Conformity

EXPLANATION OF PUMP NOMENCLATURE

Your Model #: **F**

(fill in from pump nameplate)

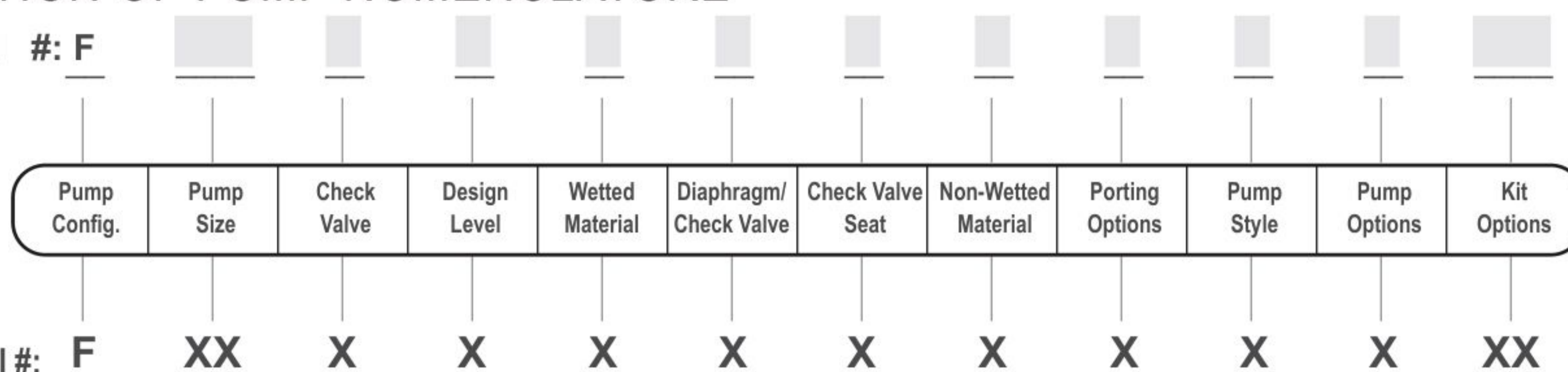

Pump Brand

F FTA®

Pump Size

30 3"

Check Valve Type

B Ball
W Weighted Ball

Design Level

1 Design Level

Wetted Material

A Aluminum
I Cast Iron
S Stainless Steel
H Alloy C
X Unpainted Aluminum

Diaphragm/Check Valve Materials

1 Santoprene/Santoprene
2 PTFE-Santoprene/PTFE
B Nitrile/Nitrile
C FKM/PTFE
E EPDM/EPDM
I EPDM/Santoprene
G PTFE-Neoprene/PTFE
M Santoprene/PTFE
N Neoprene/Neoprene

Check Valve Seat

A Aluminum
B Nitrile
C Carbon Steel
E EPDM
N Neoprene
S Stainless Steel
T PTFE
V FKM
W UHMW Polyethylene

Non-Wetted Material Options

A Painted Aluminum
I Cast Iron
J Painted Aluminum w/PTFE Coated Hardware
S Stainless Steel with Stainless Steel Hardware
Y Painted Aluminum with Stainless Steel Hardware
Z Cast Iron with Stainless Steel Hardware

Porting Options

A 150# Raised Face 3" ANSI Flange (Integral Manifold)
D 80 DIN Flange (Integral Manifold)
N NPT Threads
B BSP (Tapered) Threads

Pump Style

S Standard

Pump Options

0 None
6 Threaded Muffler (Conductive)

Kit Options

00. None
P0. 10.30VDC Pulse Output Kit
P1. Intrinsically-Safe 5.30VDC, 110/120VAC 220/240 VAC Pulse Output Kit
P2. 110/120 or 220/240VAC Pulse Output Kit
E0. Solenoid Kit with 24VDC Coil
E1. Solenoid Kit with 24VDC Explosion-Proof Coil
E2. Solenoid Kit with 24VAC/12VDC Coil
E3. Solenoid Kit with 12VDC Explosion-Proof Coil
E4. Solenoid Kit with 110VAC Coil

Kit Options (continued)

E5. Solenoid Kit with 110VAC Explosion-Proof Coil
E6. Solenoid Kit with 220VAC Coil
E7. Solenoid Kit with 220VAC Explosion-Proof Coil
E8. Solenoid Kit with 110VAC, 50 Hz Explosion-Proof Coil
E9. Solenoid Kit with 230VAC, 50 Hz Explosion-Proof Coil
SP. Stroke Indicator Pins

A1. Solenoid Kit with 12 VDC ATEX Compliant Coil
A2. Solenoid Kit with 24 VDC ATEX Compliant Coil
A3. Solenoid Kit with 110/120 VAC 50/60 Hz ATEX Compliant Coil
A4. Solenoid Kit with 220/240 VAC 50/60 Hz ATEX Compliant Coil

Your Serial #: (fill in from pump nameplate) _____

ATEX Detail

ATEX Details	Wetted Material Options	Non-Wetted Material Options	Pump Options	Kit Options
II 1 G Ex h IIC T5...225°C (T2) Ga II 1D Ex h IIIC T100°C...T200°C Da I M1 Ex h I Ma	H, I, S	I, S, Z	6	00
II 2 G Ex h IIC T5...225°C (T2) Gb II 2 D Ex h IIIC T100°C...T200°C Db	A, H, I, S, X	A, I, S, Y, Z	6	00
II 2 G Ex h ia IIC T5 Gb II 2 D Ex h ia IIIC T100°C Db	A, H, I, S, X	A, I, S, Y, Z	6	P1
II 2 G Ex h mb IIC T5 Gb II 2 D Ex h mb IIIC T100°C Db	A, H, I, S, X	A, I, S, Y, Z	6	A1, A2, A3, A4

Performance

F30 METALLIC

1: PUMP SPECS

SUCTION/DISCHARGE PORT SIZE

- 3" NPT or 3" BSP Tapered
- 3" ANSI Flange or 3" DIN Flange

CAPACITY

- 0 to 285 gallons per minute (0 to 1,078 liters per minute)

AIR DISTRIBUTION VALVE

- No-lube, no-stall design

SOLIDS-HANDLING

- Up to .38 in. (9.65mm)

HEADS UP TO

- 125 psi or 289 ft. of water (8.6 Kg/cm² or 86 meters)

DISPLACEMENT/STROKE

- 1.00 Gallon / 3.79 liter

MAXIMUM OPERATING PRESSURE

- 125 psi (8.6 bar)

SHIPPING WEIGHT

- Aluminum 116 lbs. (53kg)
- Cast Iron 215 lbs. (98kg)
- Stainless Steel 194 lbs. (87kg)

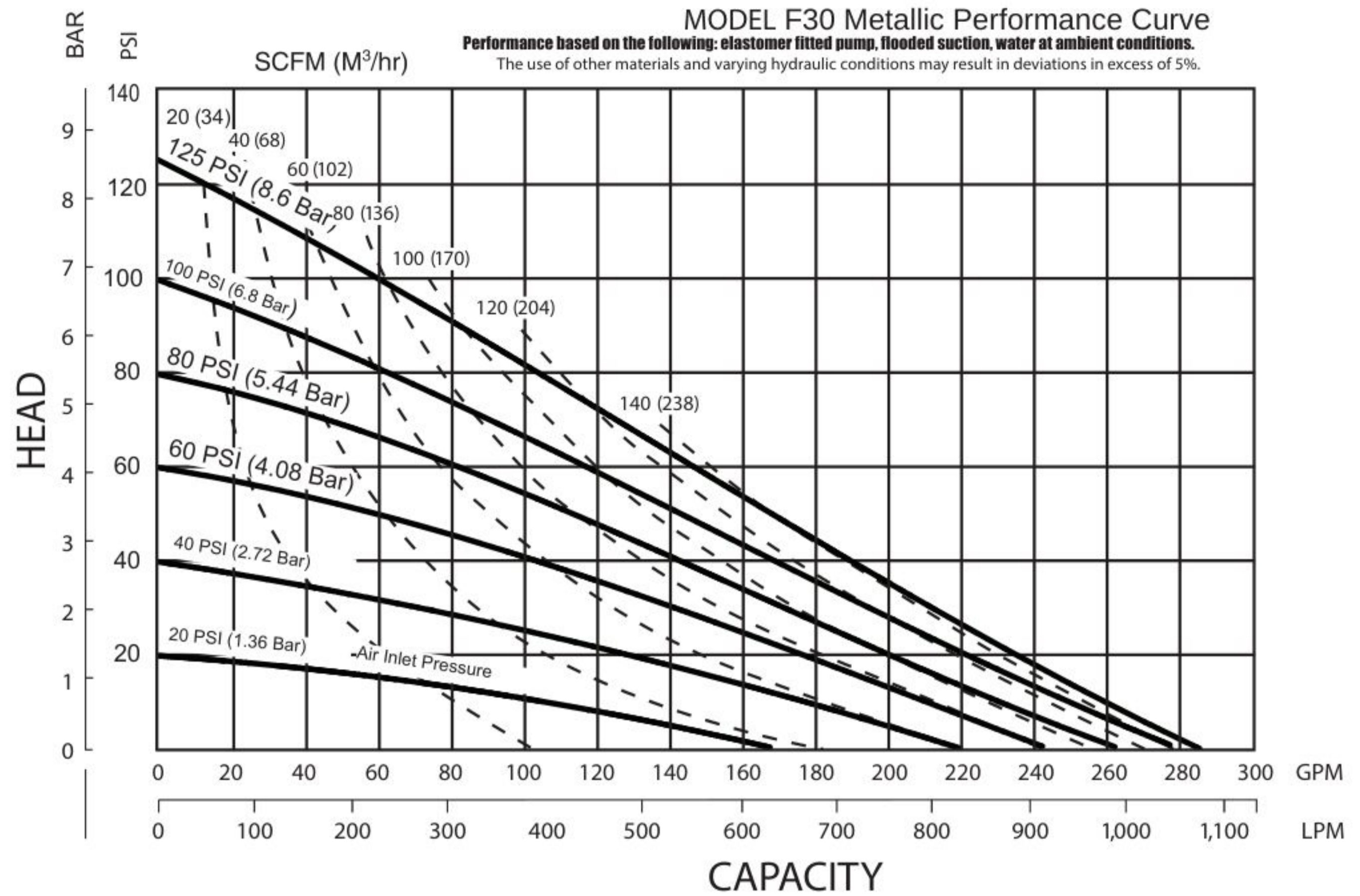

Materials

Material Profile:

CAUTION! Operating temperature limitations are as follows:

	Operating Temperatures:	
	Max.	Min.
Conductive Acetal: Tough, impact resistant, ductile. Good abrasion resistance and low friction surface. Generally inert, with good chemical resistance except for strong acids and oxidizing agents.	190°F 88°C	-20°F -29°C
EPDM: Shows very good water and chemical resistance. Has poor resistance to oils and solvents, but is fair in ketones and alcohols.	280°F 138°C	-40°F -40°C
FKM: (Fluorocarbon) Shows good resistance to a wide range of oils and solvents; especially all aliphatic, aromatic and halogenated hydrocarbons, acids, animal and vegetable oils. Hot water or hot aqueous solutions (over 70°F(21°C)) will attack FKM.	350°F 177°C	-40°F -40°C
Hytre®: Good on acids, bases, amines and glycols at room temperatures only.	220°F 104°C	-20°F -29°C
Neoprene: All purpose. Resistance to vegetable oils. Generally not affected by moderate chemicals, fats, greases and many oils and solvents. Generally attacked by strong oxidizing acids, ketones, esters and nitro hydrocarbons and chlorinated aromatic hydrocarbons.	200°F 93°C	-10°F -23°C
Nitrile: General purpose, oil-resistant. Shows good solvent, oil, water and hydraulic fluid resistance. Should not be used with highly polar solvents like acetone and MEK, ozone, chlorinated hydrocarbons and nitro hydrocarbons.	190°F 88°C	-10°F -23°C
Nylon: 6/6 High strength and toughness over a wide temperature range. Moderate to good resistance to fuels, oils and chemicals.	180°F 82°C	32°F 0°C

Polypropylene: A thermoplastic polymer. Moderate tensile and flex strength. Resists strong acids and alkali. Attacked by chlorine, fuming nitric acid and other strong oxidizing agents.	180°F 82°C	32°F 0°C
PVDF: (Polyvinylidene Fluoride) A durable fluoroplastic with excellent chemical resistance. Excellent for UV applications. High tensile strength and impact resistance.	250°F 121°C	0°F -18°C
Santoprene®: Injection molded thermoplastic elastomer with no fabric layer. Long mechanical flex life. Excellent abrasion resistance.	275°F 135°C	-40°F -40°C
UHMW PE: A thermoplastic that is highly resistant to a broad range of chemicals. Exhibits outstanding abrasion and impact resistance, along with environmental stress-cracking resistance.	180°F 82°C	-35°F -37°C
Urethane: Shows good resistance to abrasives. Has poor resistance to most solvents and oils.	150°F 66°C	32°F 0°C
Virgin PTFE: (PFA/TFE) Chemically inert, virtually impervious. Very few chemicals are known to chemically react with PTFE; molten alkali metals, turbulent liquid or gaseous fluorine and a few fluoro-chemicals such as chlorine trifluoride or oxygen difluoride which readily liberate free fluorine at elevated temperatures.	220°F 104°C	-35°F -37°C

Maximum and Minimum Temperatures are the limits for which these materials can be operated. Temperatures coupled with pressure affect the longevity of diaphragm pump components. Maximum life should not be expected at the extreme limits of the temperature ranges.

Metals:

Alloy C: Equal to ASTM494 CW-12M-1 specification for nickel and nickel alloy.
Stainless Steel: Equal to or exceeding ASTM specification A743 CF-8M for corrosion resistant iron chromium, iron chromium nickel and nickel based alloy castings for general applications. Commonly referred to as 316 Stainless Steel in the pump industry.

For specific applications, always consult the Chemical Resistance Chart.

Dimensional Drawings

F30 Metallic, Threaded Ports

Dimensional Tolerance: $\pm 1/8"$ [$\pm 3\text{mm}$]

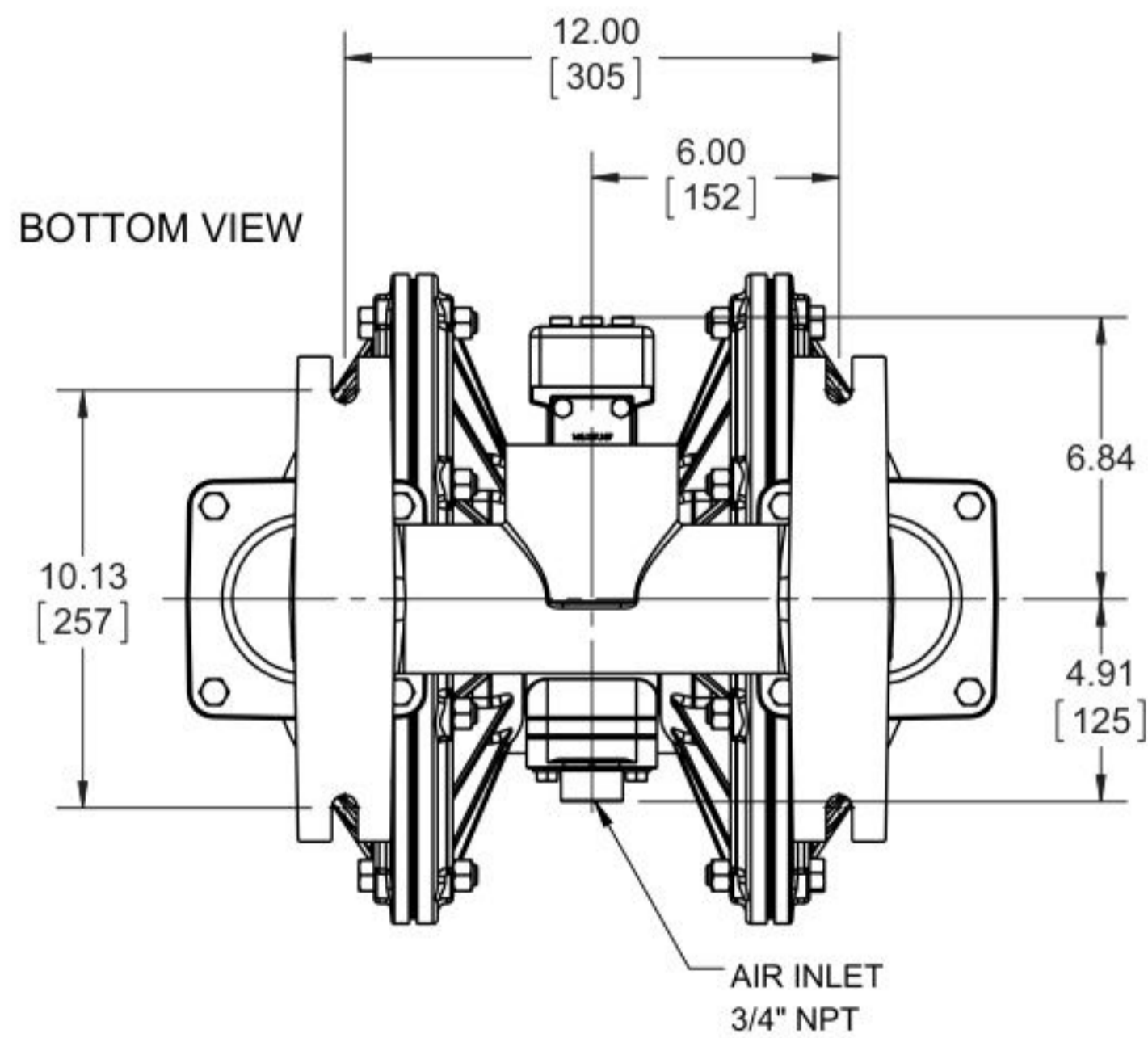
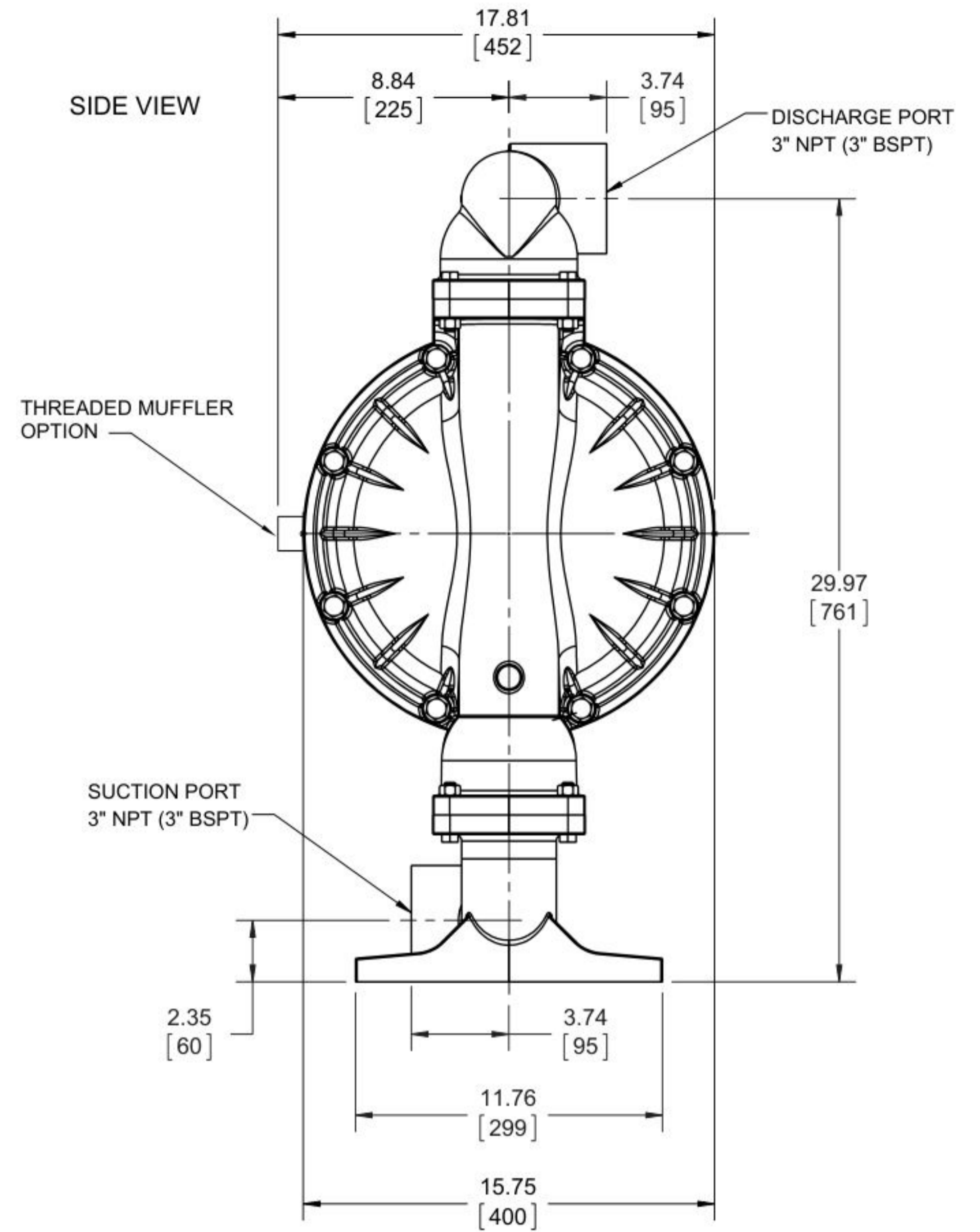
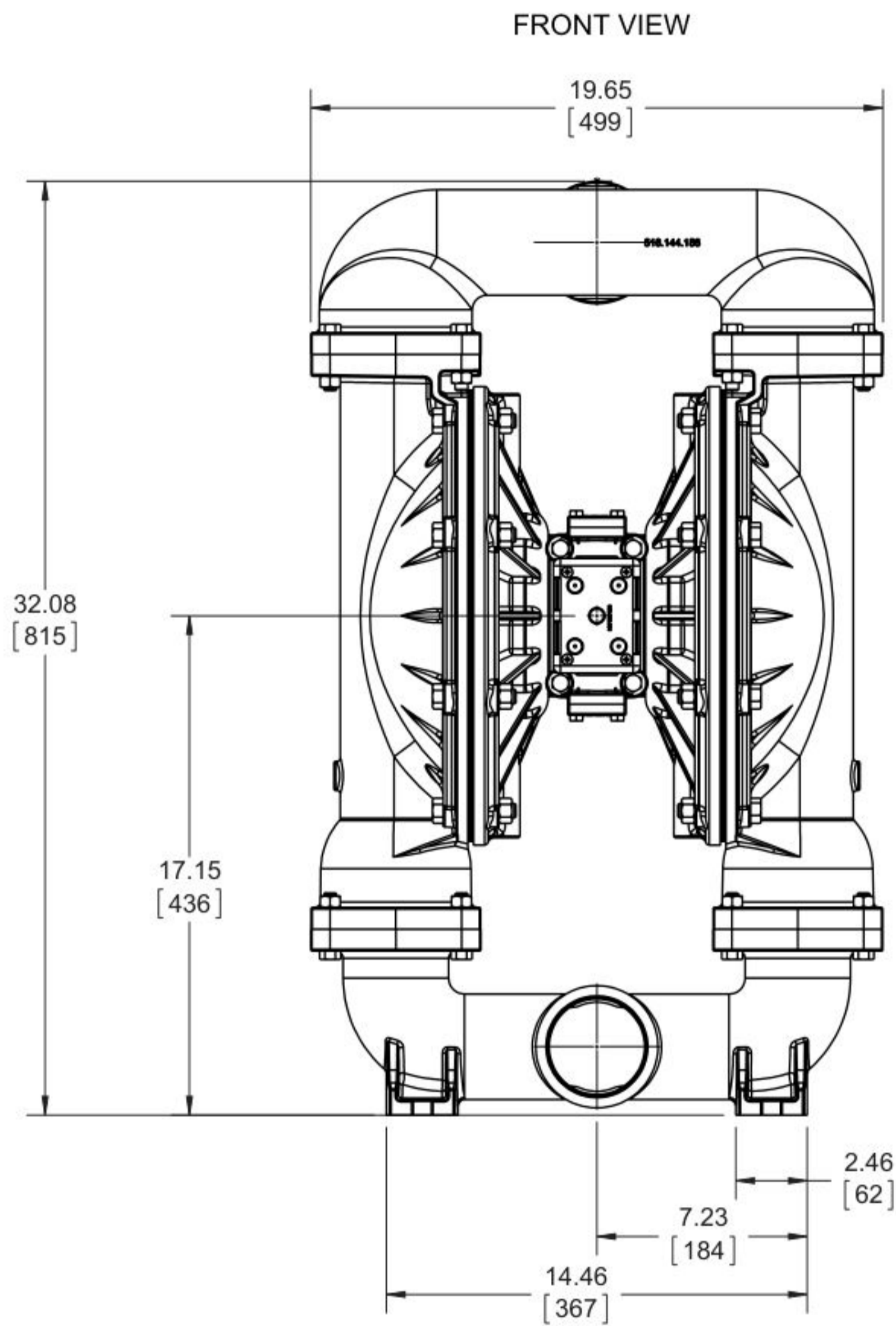

Dimensional Drawings

F30 Metallic, Flanged Ports

Dimensions in Inches. Dimensional Tolerance: $\pm 1/8"$ [$\pm 3\text{mm}$]

1: PUMP SPECS

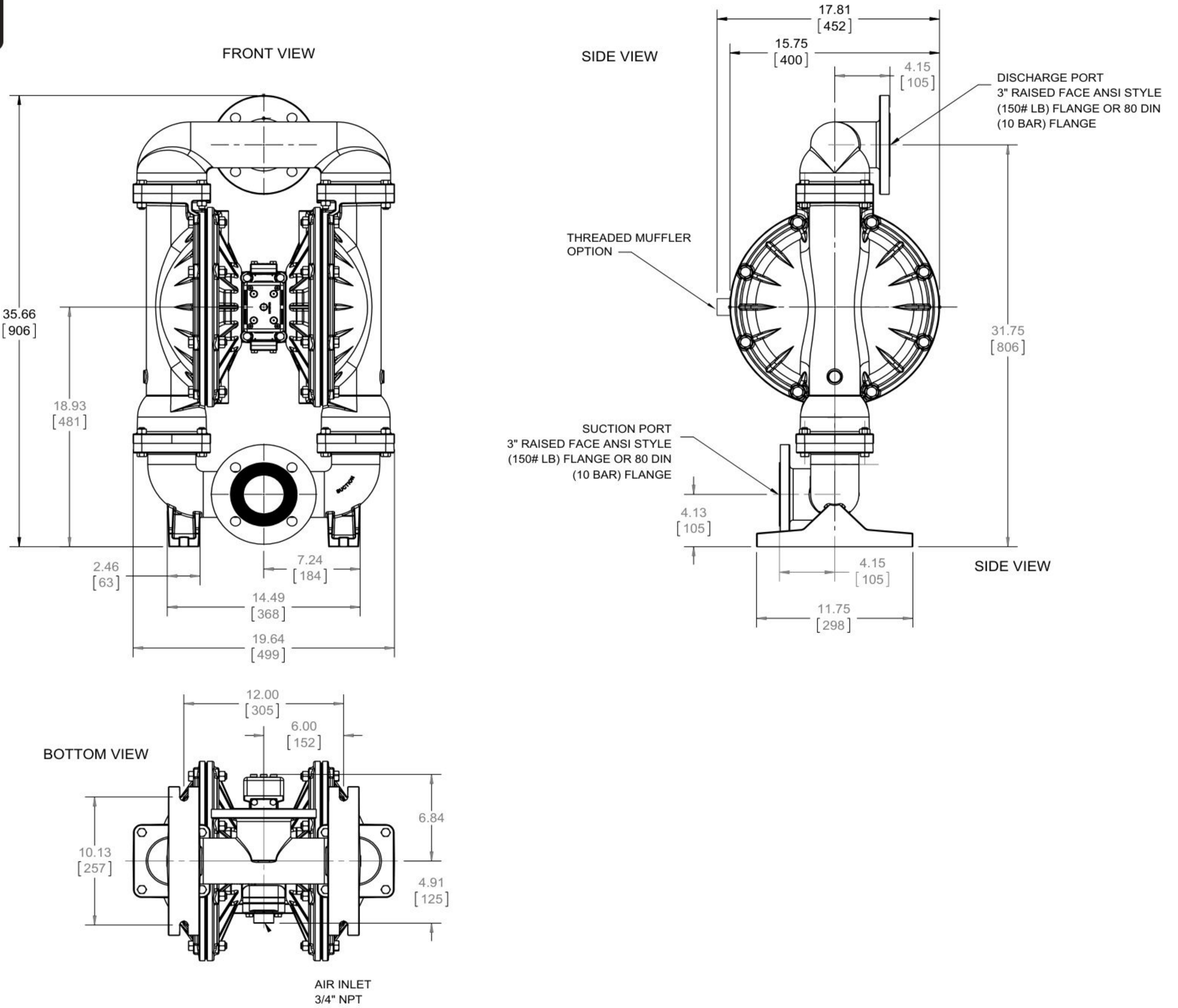

Principle of Pump Operation

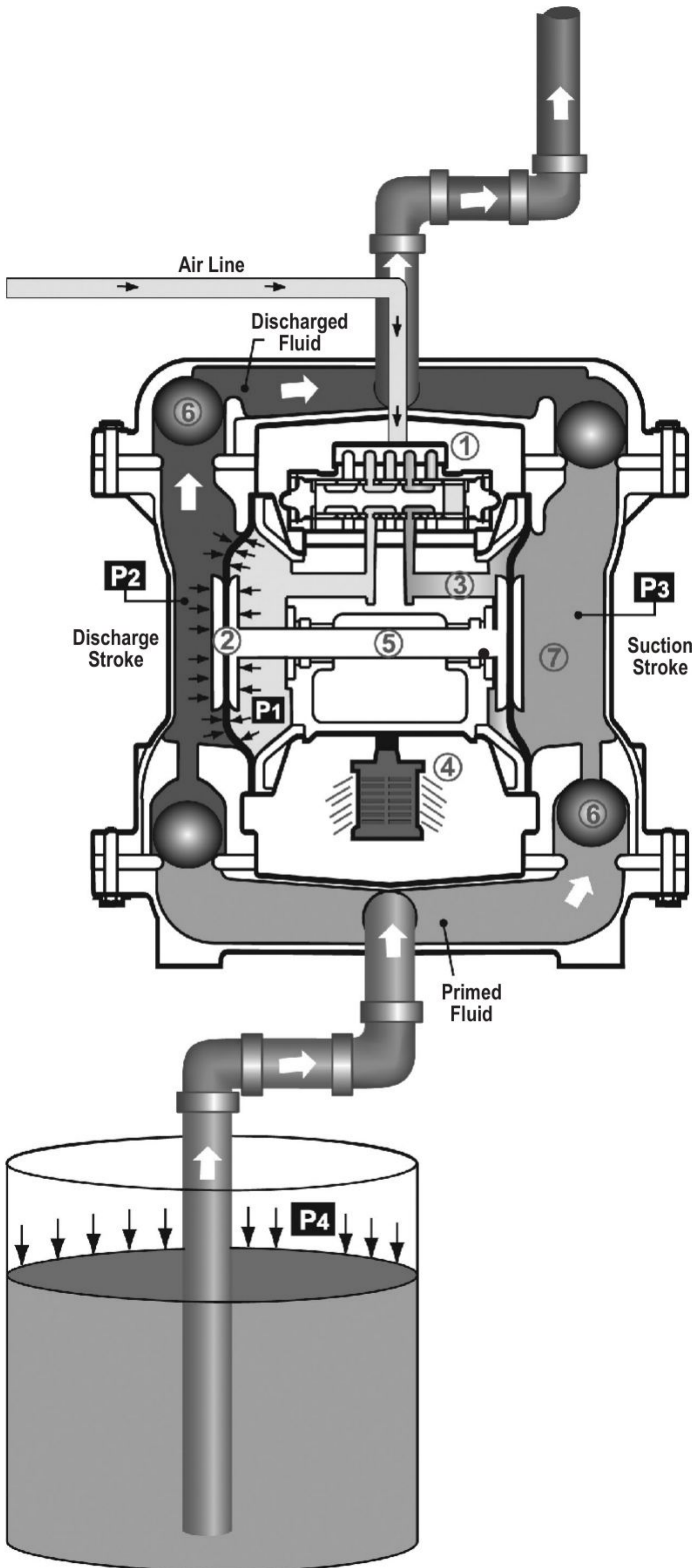

Air-Operated Double Diaphragm (AODD) pumps are powered by compressed air or nitrogen.

The main directional (air) control valve ① distributes compressed air to an air chamber, exerting uniform pressure over the inner surface of the diaphragm ②. At the same time, the exhausting air ③ from behind the opposite diaphragm is directed through the air valve assembly(s) to an exhaust port ④.

As inner chamber pressure (P1) exceeds liquid chamber pressure (P2), the rod ⑤ connected diaphragms shift together creating discharge on one side and suction on the opposite side. The discharged and primed liquid's directions are controlled by the check valves (ball or flap) ⑥ orientation.

The pump primes as a result of the suction stroke. The suction stroke lowers the chamber pressure (P3) increasing the chamber volume. This results in a pressure differential necessary for atmospheric pressure (P4) to push the fluid through the suction piping and across the suction side check valve and into the outer fluid chamber ⑦.

Suction (side) stroking also initiates the reciprocating (shifting, stroking or cycling) action of the pump. The suction diaphragm's movement is mechanically pulled through its stroke. The diaphragm's inner plate makes contact with an actuator plunger aligned to shift the pilot signaling valve. Once actuated, the pilot valve sends a pressure signal to the opposite end of the main directional air valve, redirecting the compressed air to the opposite inner chamber.

SUBMERGED ILLUSTRATION

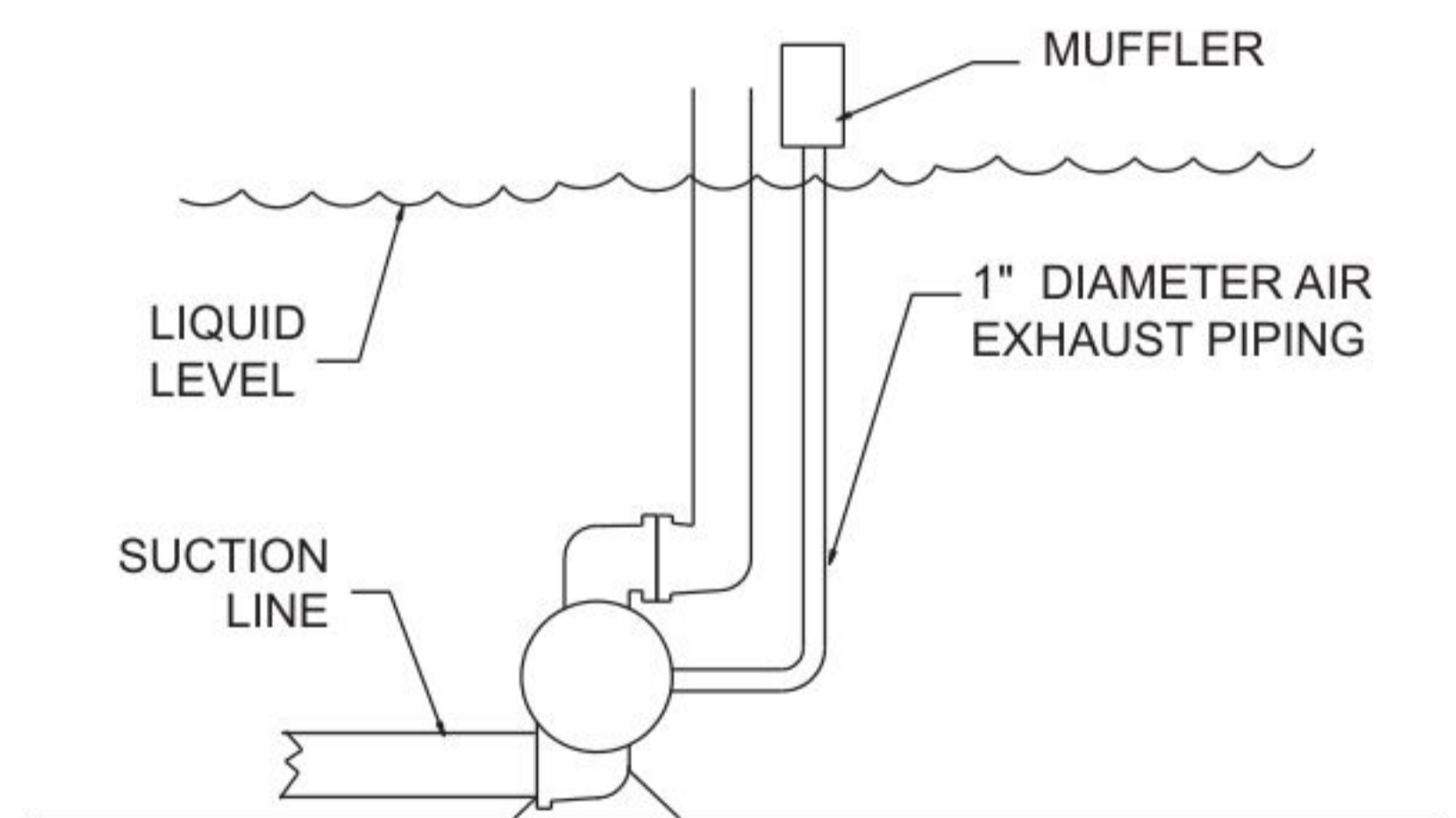

Pump can be submerged if the pump materials of construction are compatible with the liquid being pumped. The air exhaust must be piped above the liquid level. When the pumped product source is at a higher level than the pump (flooded suction condition), pipe the exhaust higher than the product source to prevent siphoning spills.

Recommended Installation Guide

Available Accessories:

1. Surge Suppressor
2. Filter/Regulator
3. Air Dryer
4. Lubricator

Note: Surge Suppressor and Piping, including air line, must be supported after the flexible connections.

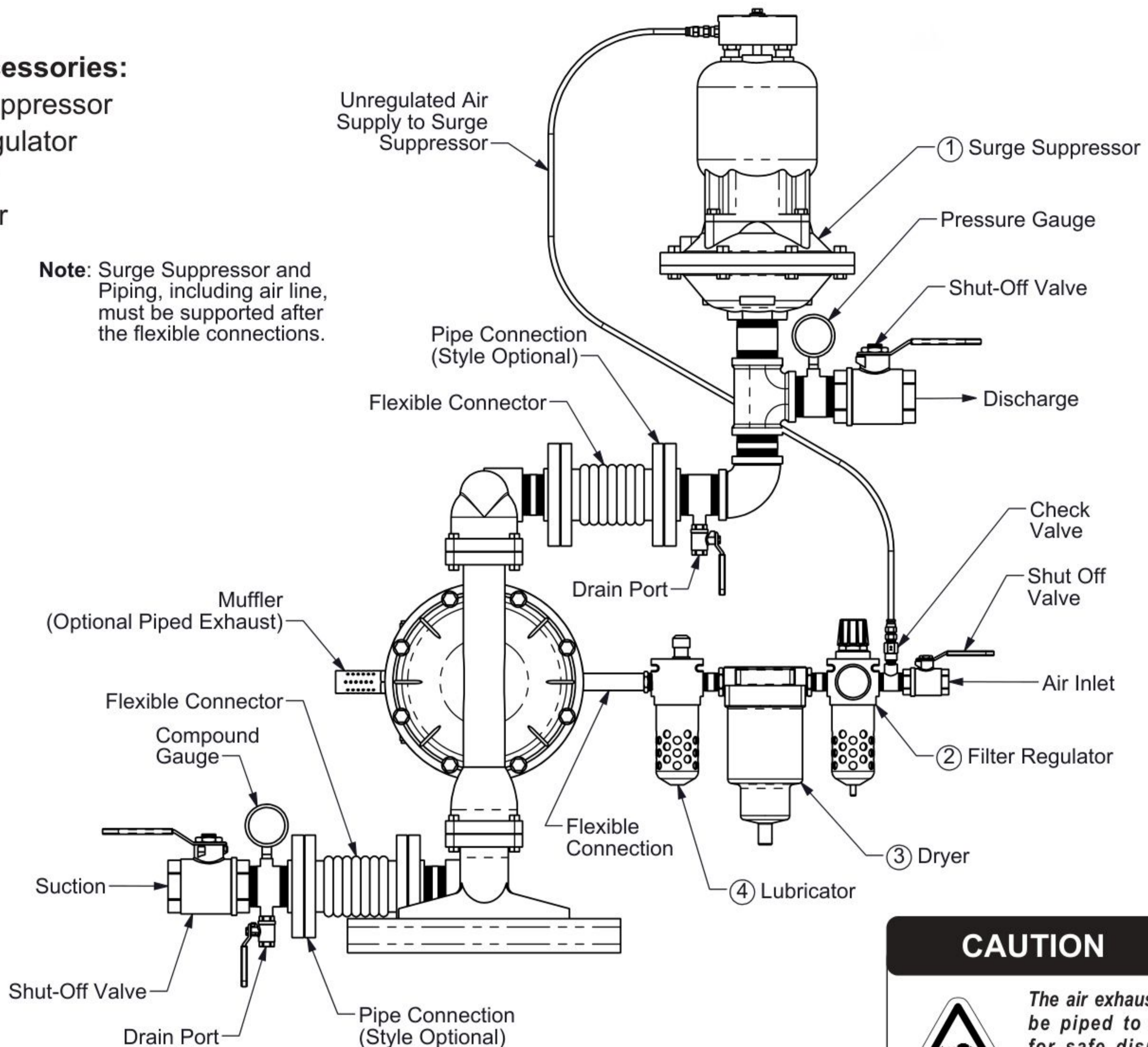

CAUTION

The air exhaust should be piped to an area for safe disposition of the product being pumped, in the event of a diaphragm failure.

Installation And Start-Up

Locate the pump as close to the product being pumped as possible. Keep the suction line length and number of fittings to a minimum. Do not reduce the suction line diameter.

Air Supply

Connect the pump air inlet to an air supply with sufficient capacity and pressure to achieve desired performance. A pressure regulating valve should be installed to insure air supply pressure does not exceed recommended limits.

Air Valve Lubrication

The air distribution system is designed to operate WITHOUT lubrication. This is the standard mode of operation. If lubrication is desired, install an air line lubricator set to deliver one drop of SAE 10 non-detergent oil for every 20 SCFM (9.4 liters/sec.) of air the pump consumes. Consult the Performance Curve to determine air consumption.

Air Line Moisture

Water in the compressed air supply may cause icing or freezing of the exhaust air, causing the pump to cycle erratically or stop operating. Water in the air supply can be reduced by using a point-of-use air dryer.

Air Inlet And Priming

To start the pump, slightly open the air shut-off valve. After the pump primes, the air valve can be opened to increase air flow as desired. If opening the valve increases cycling rate, but does not increase the rate of flow, cavitation has occurred. The valve should be closed slightly to obtain the most efficient air flow to pump flow ratio.

Troubleshooting Guide

Symptom:	Potential Cause(s):	Recommendation(s):
Pump Cycles Once	Deadhead (system pressure meets or exceeds air supply pressure).	Increase the inlet air pressure to the pump. Pump is designed for 1:1 pressure ratio at zero flow. (Does not apply to high pressure 2:1 units).
	Air valve or intermediate gaskets installed incorrectly.	Install gaskets with holes properly aligned.
	Bent or missing actuator plunger.	Remove pilot valve and inspect actuator plungers.
Pump Will Not Operate / Cycle	Pump is over lubricated.	Set lubricator on lowest possible setting or remove. Units are designed for lube free operation.
	Lack of air (line size, PSI, CFM).	Check the air line size and length, compressor capacity (HP vs. CFM required).
	Check air distribution system.	Disassemble and inspect main air distribution valve, pilot valve and pilot valve actuators.
	Discharge line is blocked or clogged manifolds.	Check for inadvertently closed discharge line valves. Clean discharge manifolds/piping.
	Deadhead (system pressure meets or exceeds air supply pressure).	Increase the inlet air pressure to the pump. Pump is designed for 1:1 pressure ratio at zero flow. (Does not apply to high pressure 2:1 units).
	Blocked air exhaust muffler.	Remove muffler screen, clean or de-ice, and re-install.
	Pumped fluid in air exhaust muffler.	Disassemble pump chambers. Inspect for diaphragm rupture or loose diaphragm plate assembly.
	Pump chamber is blocked.	Disassemble and inspect wetted chambers. Remove or flush any obstructions.
Pump Cycles and Will Not Prime or No Flow	Cavitation on suction side.	Check suction condition (move pump closer to product).
	Check valve obstructed. Valve ball(s) not seating properly or sticking.	Disassemble the wet end of the pump and manually dislodge obstruction in the check valve pocket. Clean out around valve ball cage and valve seat area. Replace valve ball or valve seat if damaged. Use heavier valve ball material.
	Valve ball(s) missing (pushed into chamber or manifold).	Worn valve ball or valve seat. Worn fingers in valve ball cage (replace part). Check Chemical Resistance Guide for compatibility.
	Valve ball(s) / seat(s) damaged or attacked by product.	Check Chemical Resistance Guide for compatibility.
	Check valve and/or seat is worn or needs adjusting.	Inspect check valves and seats for wear and proper setting. Replace if necessary.
	Suction line is blocked.	Remove or flush obstruction. Check and clear all suction screens or strainers.
	Excessive suction lift.	For lifts exceeding 20' of liquid, filling the chambers with liquid will prime the pump in most cases.
	Suction side air leakage or air in product.	Visually inspect all suction-side gaskets and pipe connections.
	Pumped fluid in air exhaust muffler.	Disassemble pump chambers. Inspect for diaphragm rupture or loose diaphragm plate assembly.
	Pump Cycles Running Sluggish / Stalling, Flow Unsatisfactory	Over lubrication.
Icing.		Remove muffler screen, de-ice, and re-install. Install a point of use air drier.
Clogged manifolds.		Clean manifolds to allow proper air flow.
Deadhead (system pressure meets or exceeds air supply pressure).		Increase the inlet air pressure to the pump. Pump is designed for 1:1 pressure ratio at zero flow. (Does not apply to high pressure 2:1 units).
Cavitation on suction side.		Check suction (move pump closer to product).
Lack of air (line size, PSI, CFM).		Check the air line size, length, compressor capacity.
Excessive suction lift.		For lifts exceeding 20' of liquid, filling the chambers with liquid will prime the pump in most cases.
Air supply pressure or volume exceeds system hd.		Decrease inlet air (press. and vol.) to the pump. Pump is cavitating the fluid by fast cycling.
Undersized suction line.		Meet or exceed pump connections.
Restrictive or undersized air line.		Install a larger air line and connection.
Suction side air leakage or air in product.		Visually inspect all suction-side gaskets and pipe connections.
Suction line is blocked.		Remove or flush obstruction. Check and clear all suction screens or strainers.
Pumped fluid in air exhaust muffler.		Disassemble pump chambers. Inspect for diaphragm rupture or loose diaphragm plate assembly.
Check valve obstructed.		Disassemble the wet end of the pump and manually dislodge obstruction in the check valve pocket.
Check valve and/or seat is worn or needs adjusting.		Inspect check valves and seats for wear and proper setting. Replace if necessary.
Entrained air or vapor lock in chamber(s).		Purge chambers through tapped chamber vent plugs. Purging the chambers of air can be dangerous.
Product Leaking Through Exhaust	Diaphragm failure, or diaphragm plates loose.	Replace diaphragms, check for damage and ensure diaphragm plates are tight.
	Diaphragm stretched around center hole or bolt holes.	Check for excessive inlet pressure or air pressure. Consult Chemical Resistance Chart for compatibility with products, cleaners, temperature limitations and lubrication.
Premature Diaphragm Failure	Cavitation.	Enlarge pipe diameter on suction side of pump.
	Excessive flooded suction pressure.	Move pump closer to product. Raise pump/place pump on top of tank to reduce inlet pressure. Install Back pressure device (Tech bulletin 41r). Add accumulation tank or pulsation dampener.
	Misapplication (chemical/physical incompatibility).	Consult Chemical Resistance Chart for compatibility with products, cleaners, temperature limitations and lubrication.
	Incorrect diaphragm plates or plates on backwards, installed incorrectly or worn.	Check Operating Manual to check for correct part and installation. Ensure outer plates have not been worn to a sharp edge.
Unbalanced Cycling	Excessive suction lift.	For lifts exceeding 20' of liquid, filling the chambers with liquid will prime the pump in most cases.
	Undersized suction line.	Meet or exceed pump connections.
	Pumped fluid in air exhaust muffler.	Disassemble pump chambers. Inspect for diaphragm rupture or loose diaphragm plate assembly.
	Suction side air leakage or air in product.	Visually inspect all suction-side gaskets and pipe connections.
	Check valve obstructed.	Disassemble the wet end of the pump and manually dislodge obstruction in the check valve pocket.
	Check valve and/or seat is worn or needs adjusting.	Inspect check valves and seats for wear and proper setting. Replace if necessary.
	Entrained air or vapor lock in chamber(s).	Purge chambers through tapped chamber vent plugs.

Composite Repair Parts Drawing

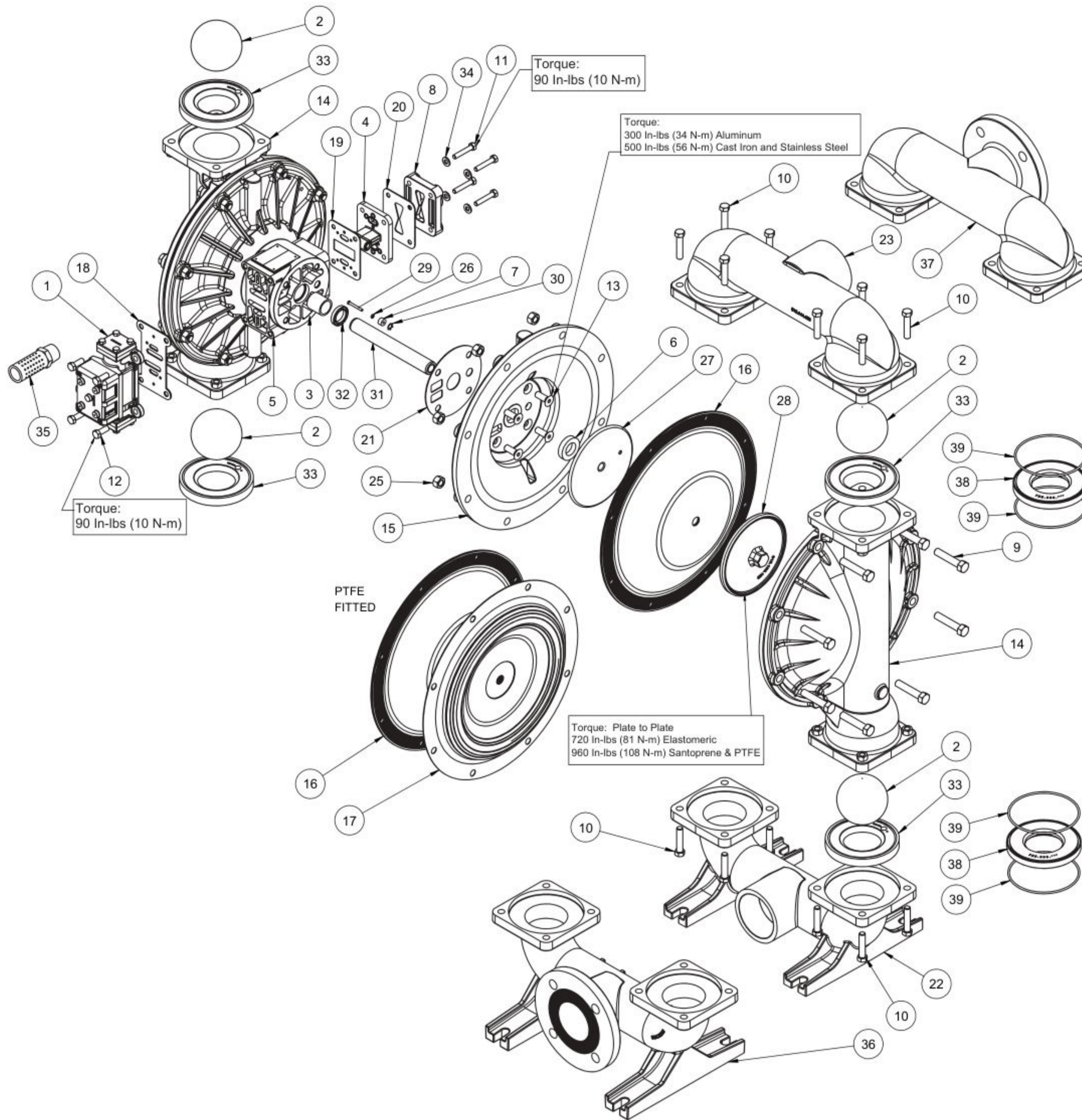

3: EXP VIEW

Service & Repair Kits

- 476-227-000 Air End Kit (Aluminum Center)**
Air Valve Assembly, Pilot Valve Assembly, Seals, O-Rings, Gaskets, Plungers.
- **476-170-000 Air End Kit** (Air Valve with Stroke Indicator Pin, Aluminum Center) Seals, O-Ring, Gaskets, Retaining Rings, Air Valve Sleeve and Spool Set, and Pilot Valve Assembly.
- 476-171-360 Wet End Kit**
Nitrile Diaphragms, Balls, and Seats.
- 476-171-656 Wet End Kit**
Santoprene Diaphragms, Balls and EPDM Seats.
- 476-171-364 Wet End Kit**
EPDM Diaphragms, Balls and Seats.
- 476-171-365 Wet End Kit**
Neoprene Diaphragms, Balls, and Seats.
- 476-171-633 Wet End Kit**
FKM Diaphragms, PTFE Balls and PTFE Seats.
- 476-171-635 Wet End Kit**
Neoprene Diaphragms, PTFE Overlay, PTFE Balls and PTFE Seats.

- 476-171-644 Wet End Kit**
Santoprene Diaphragms, PTFE Balls and PTFE Seats
 - 476-171-654 Wet End Kit**
Santoprene Diaphragms, PTFE Overlays, PTFE Balls, PTFE Seats.
 - 475-217-000 Micsection Conversion Kit**
(Replaces Aluminum Midsection with Cast Iron Components) Air Inlet Cap, Intermediate Bracket, Inner Chambers, and Inner Diaphragm Plates.
- Hardware Kits (For pumps with aluminum center sections)**
- 475-197-330 Zinc Plated Capscrews, Washers, and Hex Nuts.
 - 475-197-115 Stainless Steel Capscrews, Washers, and Hex Nuts.
- **Electronic Leak Detector Kits**
- 032-040-000 110VAC
 - 032-037-000 220VAC

****Note:** Pumps equipped with these components are not ATEX compliant

Composite Repair Parts List

Item	Part Number	Description	Qty	Item	Part Number	Description	Qty
①	031.173.000	Air Valve Assembly (000 muffler)	1	23	518.144.156	Manifold, Discharge - NPT (w/ alum wetted)	1
	031.173.001	Air Valve Assembly (000 muffler w/ SS hardware)	1		518.144.010	Manifold, Discharge - NPT (w/ cast iron wetted)	1
	⚠ 031.179.000	Air Valve Assembly (w/ cast iron or stainless center)	1		518.144.110	Manifold, Discharge - NPT (w/ stainless wetted)	1
	⚠ 031.183.000	Air Valve Assembly (w/ no muffler)	1		518.144.112	Manifold, Discharge - NPT (w/ hastelloy wetted)	1
	⚠ 031.146.000	Air Valve Assembly (stroke Indicator w/ 0 muffler)	1		518.144.156E	Manifold, Discharge - BSPT (w/ alum wetted)	1
	⚠ 031.147.000	Air Valve Assembly (stroke Indicator w/ no muffler)	1		518.144.010E	Manifold, Discharge - BSPT (w/ cast iron wetted)	1
②	050.014.354	Ball, Check - Santoprene	4		518.144.110E	Manifold, Discharge - BSPT (w/ stainless wetted)	1
	050.014.351	Ball, Check - Food Grade Santoprene	4		518.144.112E	Manifold, Discharge - BSPT (w/ hastelloy wetted)	1
	050.014.360	Ball, Check - Buna	4	24	545.007.330	Nut, Hex 7/16-14	16
	050.014.360W	Ball, Check - Buna (weighted)	4		545.007.115	Nut, Hex 7/16-14 (w/ stainless hardware)	16
	050.014.364W	Ball, Check - EPDM (weighted)	4	25	545.008.330	Nut, Hex 1/2-13	16
	050.014.365	Ball, Check - Neoprene	4		545.008.115	Nut, Hex 1/2-13 (w/ stainless hardware)	16
	050.014.365W	Ball, Check - Neoprene (weighted)	4	②⑥	560.001.360	O-ring	2
	050.015.600	Ball, Check - PTFE	4	27	612.192.157	Plate, Inner Diaphragm (w/ aluminum center)	2
3	070.006.170	Bushing, Intermediate (included in item #5)	2		612.192.010	Plate, Inner Diaphragm (w/ cast iron center)	2
④	095.110.000	Pilot Valve Assembly	1		612.192.334	Plate, Inner Diaphragm (w/ stainless center)	2
	095.110.110	Pilot Valve Assembly (w/ stainless center)	1	28	612.194.157	Plate, Outer Diaphragm (w/ aluminum wetted)	2
	095.110.558	Pilot Valve Assembly (w/ cast iron center)	1		612.194.010	Plate, Outer Diaphragm (w/ cast iron wetted)	2
5	114.024.157	Intermediate (w/ aluminum center)	1		612.194.110	Plate, Outer Diaphragm (w/ stainless wetted)	2
	114.024.010	Intermediate (w/ cast iron center)	1		612.194.112	Plate, Outer Diaphragm (w/ hastelloy wetted)	2
	114.024.110	Intermediate (w/ stainless center)	1	②⑨	620.020.115	Plunger, Actuator	2
⑥	132.035.357	Bumper, Diaphragm	2	③①	675.042.115	Ring, Retaining	2
⑦	135.034.506	Bushing, Plunger	2	31	685.040.120	Rod, Diaphragm	1
8	165.159.157	Cap, Air Inlet (w/ aluminum center)	1	③②	720.004.360	Seal, Diaphragm Rod U-Cup	2
	165.159.010	Cap, Air Inlet (w/ cast iron center)	1	③③	722.090.360	Seat, Check Ball - Buna	4
	165.159.110	Cap, Air Inlet (w/ stainless center)	1		722.090.363	Seat, Check Ball - FKM (Viton)	4
9	170.055.330	Capscrew, Hx-Hd 1/2-13 X 2.50	16		722.090.364	Seat, Check Ball - EPDM	4
	170.055.115	Capscrew, Hx-Hd 1/2-13 X 2.50 (w/ SS hardware)	16		722.090.365	Seat Check Ball - Neoprene	4
10	170.060.330	Capscrew, Hx-Hd 7/16-14 x 2.00	16		722.090.550	Seat, Check Ball - UHMW	4
	170.060.115	Capscrew, Hx-Hd 7/16-14 x 2.00 (w/ SS hardware)	16		722.090.600	Seat, Check Ball - PTFE	4
11	170.069.330	Capscrew, Hx-Hd 5/16-18 x 1.75	4	34	901.038.330	Washer, Flat 5/16	4
	170.069.115	Capscrew, Hx-Hd 5/16-18 x 1.75 (w/ SS hardware)	4		901.038.115	Washer, Flat 5/16 (w/ stainless hardware)	4
12	170.006.330	Capscrew, Hx-Hd 3/8-18 X 1.00	4	35	⚠ 530.058.000	Muffler, Threaded (Conductive)	1
	170.006.115	Capscrew, Hx-Hd 3/8-18 X 1.00 (w/ SS hardware)	4	36	⚠ 518.171.156	Manifold, Suction - ANSI Style Flanged (aluminum)	1
	171.053.330	Capscrew, Soc-Hd 3/8-16 X 2.50	4		518.171.010	Manifold, Suction - ANSI Style Flanged (cast iron)	1
		(w/ stroke indicator)*			518.171.110	Manifold, Suction - ANSI Style Flanged (stainless)	1
	171.053.115	Capscrew, Soc-Hd 3/8-16 X 2.50	4		518.171.156E	Manifold, Suction - DIN Style Flanged (aluminum)	1
		(w/ stroke indicator, w/ stainless hardware)*			518.171.010E	Manifold, Suction - DIN Style Flanged (cast iron)	1
	*901.048.330	Washer, Flat 3/8 (use with item #12 w/ stroke indicator) not shown	4		518.171.110E	Manifold, Suction - DIN Style Flanged (stainless)	1
	*901.048.115	Washer, Flat 3/8 (use with item #12 w/ stroke indicator and stainless steel hardware) not shown	4	37	518.172.156	Manifold, Discharge - ANSI Style Flanged (aluminum)	1
13	171.059.330	Capscrew, Soc-Flat Hd 7/16-14 x 1.25	8		518.172.010	Manifold, Discharge - ANSI Style Flanged (cast iron)	1
	171.059.115	Capscrew, Soc-Flat Hd 7/16-14 x 1.25 (w/ aluminum center, w/ stainless hardware)	8		518.172.110	Manifold, Discharge - ANSI Style Flanged (stainless)	1
	171.011.115	Capscrew, Soc-Flat Hd 1/2-13 x 1.00 (w/ SS center)	8		518.172.156E	Manifold, Discharge - DIN Style Flanged (aluminum)	1
14	196.200.156	Chamber, Outer (w/ aluminum wetted)	2	38	722.090.150	Seat, Check Ball - Aluminum (requires 8 qty Item #39)	4
	196.164.015	Chamber, Outer (w/ cast iron wetted)	2		722.090.080	Seat, Check Ball - Steel (requires 8 qty Item #39)	4
	196.164.110	Chamber, Outer (w/ stainless wetted)	2		722.090.110	Seat, Check Ball - Stainless (requires 8 qty Item #39)	4
	196.164.112	Chamber, Outer (w/ hastelloy wetted)	2	39	560.105.360	Seal, O-ring - Buna (used with Item #38)	8
15	196.165.156	Chamber, Inner (w/ aluminum center-sand cast)	2		560.105.363	Seal, O-ring - FKM (Viton) (used with Item #38)	8
	196.165.157	Chamber, Inner (w/ aluminum center-die cast)	2		560.105.364	Seal, O-ring - EPDM (used with Item #38)	8
	196.165.010	Chamber, Inner (w/ cast iron center)	2		560.105.365	Seal, O-ring - Neoprene (used with Item #38)	8
	196.165.110	Chamber, Inner (w/ stainless center)	2		720.055.608	Seal, PTFE (used with Item #38)	8
①⑥	286.098.354	Diaphragm - Santoprene	2				
	286.098.360	Diaphragm - Buna	2				
	286.098.363	Diaphragm - FKM (Viton)	2				
	286.098.364	Diaphragm - EPDM	2				
	286.098.365	Diaphragm - Neoprene	2				
①⑦	286.098.604	Diaphragm, Overlay - PTFE	2				
①⑧	360.093.360	Gasket, Air Valve	1				
①⑨	360.114.360	Gasket, Pilot Valve	1				
②①	360.104.379	Gasket, Air Inlet Cap	1				
②②	360.105.360	Gasket, Inner Chamber	2				
	518.143.156	Manifold, Suction - NPT (w/ aluminum wetted)	1				
	518.143.010	Manifold, Suction - NPT (w/ cast iron wetted)	1				
	518.143.110	Manifold, Suction - NPT (w/ stainless wetted)	1				
	518.143.112	Manifold, Suction - NPT (w/ hastelloy wetted)	1				
	518.143.156E	Manifold, Suction - BSPT (w/ aluminum wetted)	1				
	518.143.010E	Manifold, Suction - BSPT (w/ cast iron wetted)	1				
	518.143.110E	Manifold, Suction - BSPT (w/ stainless wetted)	1				
	518.143.112E	Manifold, Suction - BSPT (w/ hastelloy wetted)	1				

LEGEND:

○ = Items contained within Air End Kits

□ = Items contained within Wet End Kits

Note: Kits contain components specific to the material codes.

3: EXP VIEW

Material Codes - The Last 3 Digits of Part Number

000.....Assembly, sub-assembly; and some purchased items	364.....EPDM Rubber Color coded: BLUE	• Delrin and Hytrel are registered tradenames of E.I. DuPont.
010.....Cast Iron	365.....Neoprene Rubber Color coded: GREEN	• Nylatron is a registered tradename of Polymer Corp.
015.....Ductile Iron	366.....Food Grade Nitrile	• Gylon is a registered tradename of Garlock, Inc.
020.....Ferritic Malleable Iron	368.....Food Grade EPDM	• Santoprene is a registered tradename of Exxon Mobil Corp.
080.....Carbon Steel, AISI B-1112	371.....Philthane (Tuftane)	• Rulon II is a registered tradename of Dixion Industries Corp.
110.....Alloy Type 316 Stainless Steel	374.....Carboxylated Nitrile	• Ryton is a registered tradename of Phillips Chemical Co.
111.....Alloy Type 316 Stainless Steel (Electro Polished)	375.....Fluorinated Nitrile	• Valox is a registered tradename of General Electric Co.
112.....Alloy C	378.....High Density Polypropylene	
113.....Alloy Type 316 Stainless Steel (Hand Polished)	379.....Conductive Nitrile	
114.....303 Stainless Steel	408.....Cork and Neoprene	
115.....302/304 Stainless Steel	425.....Compressed Fibre	
117.....440-C Stainless Steel (Martensitic)	426.....Blue Gard	
120.....416 Stainless Steel (Wrought Martensitic)	440.....Vegetable Fibre	
148.....Hardcoat Anodized Aluminum	500.....Delrin® 500	
150.....6061-T6 Aluminum	502.....Conductive Acetal, ESD-800	
152.....2024-T4 Aluminum (2023-T351)	503.....Conductive Acetal, Glass-Filled	
155.....356-T6 Aluminum	506.....Delrin® 150	
156.....356-T6 Aluminum	520.....Injection Molded PVDF Natural color	
157.....Die Cast Aluminum Alloy #380	540.....Nylon	
158.....Aluminum Alloy SR-319	542.....Nylon	
162.....Brass, Yellow, Screw Machine Stock	544.....Nylon Injection Molded	
165.....Cast Bronze, 85-5-5-5	550.....Polyethylene	
166.....Bronze, SAE 660	551.....Glass Filled Polypropylene	
170.....Bronze, Bearing Type, Oil Impregnated	552.....Unfilled Polypropylene	
180.....Copper Alloy	555.....Polyvinyl Chloride	
305.....Carbon Steel, Black Epoxy Coated	556.....Black Vinyl	
306.....Carbon Steel, Black PTFE Coated	557.....Unfilled Conductive Polypropylene	
307.....Aluminum, Black Epoxy Coated	558.....Conductive HDPE	
308.....Stainless Steel, Black PTFE Coated	559.....Glass Filled - Conductive Polypropylene	
309.....Aluminum, Black PTFE Coated	570.....Rulon II®	
313.....Aluminum, White Epoxy Coated	580.....Ryton®	
330.....Zinc Plated Steel	600.....PTFE (virgin material) Tetrafluorocarbon (TFE)	
332.....Aluminum, Electroless Nickel Plated	603.....Blue Gylon®	
333.....Carbon Steel, Electroless Nickel Plated	604.....PTFE	
335.....Galvanized Steel	606.....PTFE	
337.....Silver Plated Steel	607.....Envelon	
351.....Food Grade Santoprene®	608.....Conductive PTFE	
353.....Geolast; Color: Black	610.....PTFE Encapsulated Silicon	
354.....Injection Molded #203-40 Santoprene® Duro 40D +/-5; Color: RED	611.....PTFE Encapsulated FKM	
356.....Hytrel®	632.....Neoprene/Hytrel®	
357.....Injection Molded Polyurethane	633.....FKM/PTFE	
358.....Urethane Rubber (Some Applications) (Compression Mold)	634.....EPDM/PTFE	
359.....Urethane Rubber	635.....Neoprene/PTFE	
360.....Nitrile Rubber Color coded: RED	637.....PTFE, FKM/PTFE	
363.....FKM (Fluorocarbon) Color coded: YELLOW	638.....PTFE, Hytrel®/PTFE	
	639.....Nitrile/TFE	
	643.....Santoprene®/EPDM	
	644.....Santoprene®/PTFE	
	656.....Santoprene® Diaphragm and Check Balls/EPDM Seats	
	661.....EPDM/Santoprene®	
	666.....FDA Nitrile Diaphragm, PTFE Overlay, Balls, and Seals	
	668.....PTFE, FDA Santoprene®/PTFE	

Air Distribution Valve Assembly

(Use with Aluminum Centers ONLY)

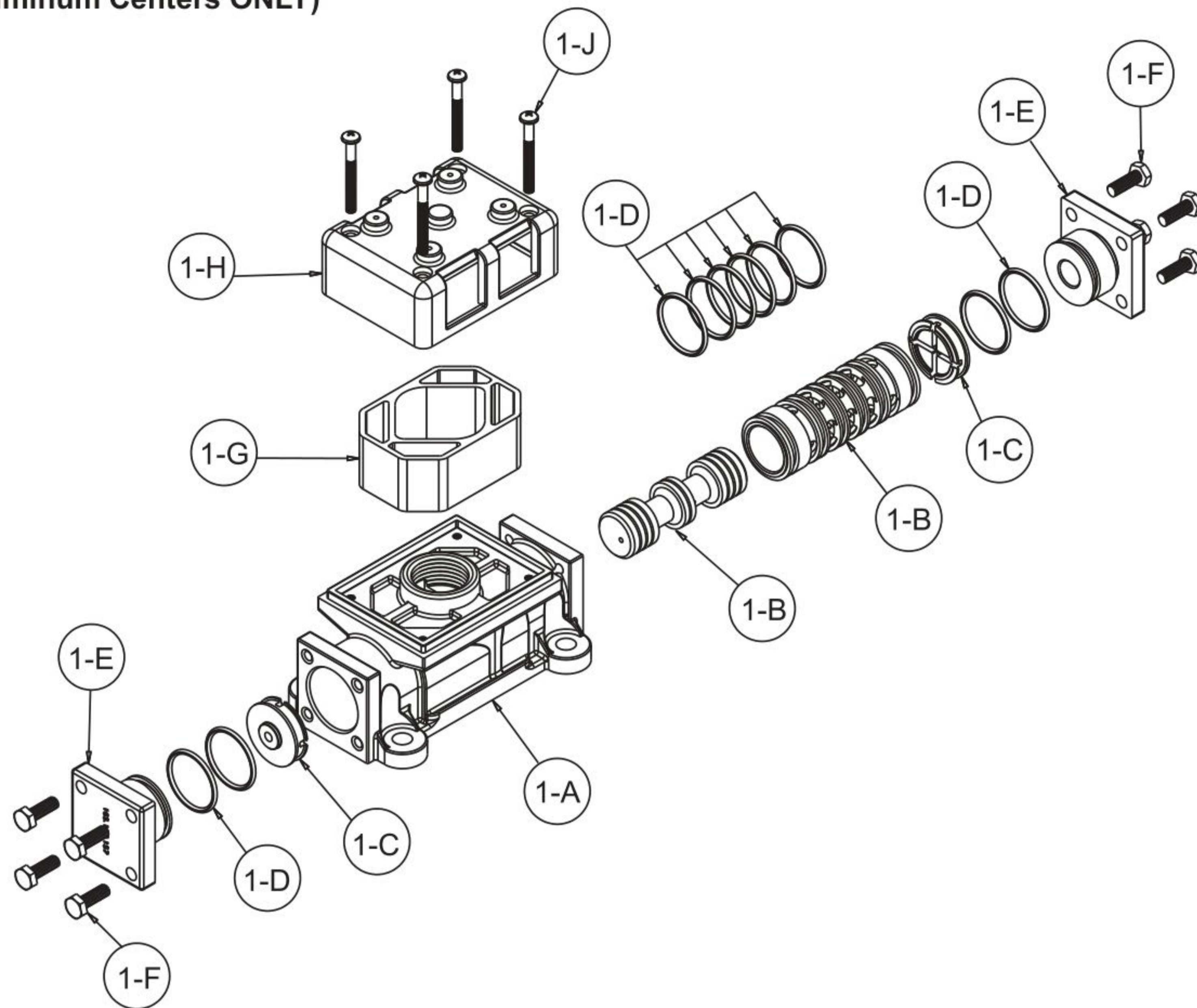

Air Distribution Valve Servicing

See repair parts drawing, remove screws.

Step 1: Remove Hex Head Cap Screws (1-F).

Step 2: Remove end cap (1-E).

Step 3: Remove spool part of (1-B) (caution: do not scratch).

Step 4: Press sleeve (1-B) from body (1-A).

Step 5: Inspect O-Ring (1-D) and replace if necessary.

Step 6: Lightly lubricate O-Rings (1-D) on sleeve (1-B).

Step 7: Press sleeve (1-B) into body (1-A).

Step 8: Reassemble in reverse order, starting with step 3.

Note: Sleeve and spool (1-B) set is match ground to a specified clearance sleeve and spools (1-B) cannot be interchanged.

Air Valve Assembly Parts List

Item	Part Number	Description	Qty
1	031.173.000	Air Valve Assembly	1
1-A	095.109.157	Body, Air Valve	1
1-B	031.139.000	Sleeve and Spool Set	1
1-C	132.029.552	Bumper	2
1-D	560.020.360	O-Ring	10
1-E	165.127.157	Cap, End	2
1-F	170.032.330	Hex Head Capscrew 1/4-20 x .75	8
1-G	530.028.550	Muffer	1
1-H	165.096.551	Muffer Cap	1
1-J	706.026.330	Machine Screw	4

**Air Valve Assembly Parts List

1	031.173.001	Air Valve Assembly	1
Consists of all components above except:			
1-F	170.032.115	Hex Head Capscrew 1/4-20 x .75	8
1-J	706.026.115	Machine Screw	4

****Note:** Pumps equipped with this valve assembly are not ATEX compliant

⚠ IMPORTANT



Read these instructions completely, before installation and start-up. It is the responsibility of the purchaser to retain this manual for reference. Failure to comply with the recommendations stated in this manual will damage the pump, and void factory warranty.

Air Valve with Stroke Indicator Assembly

Note: Stroke Indicator is standard on Spill Containment models

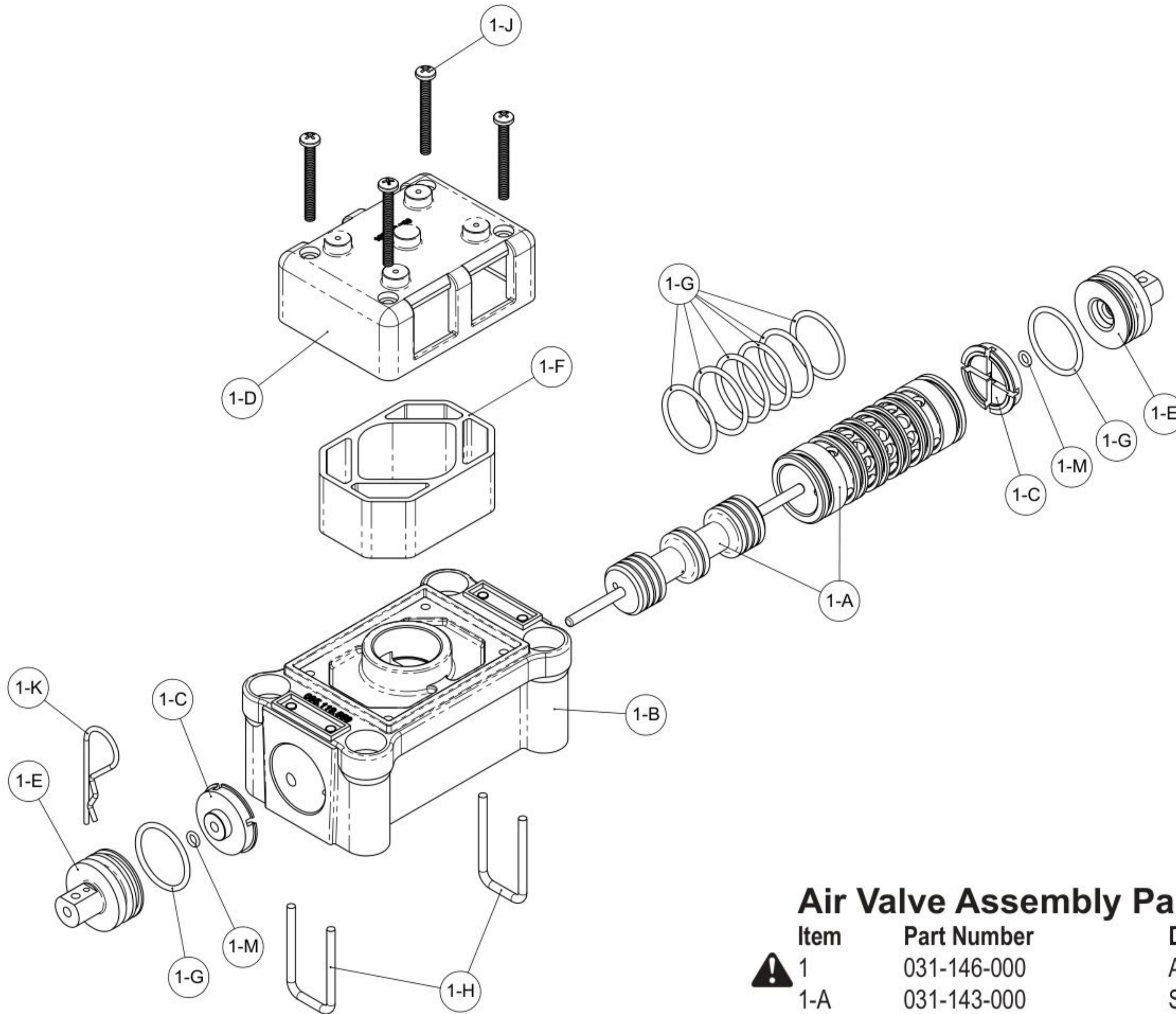

Air Distribution Valve Servicing

See repair parts drawing, remove screws.

Step 1: Remove staple retainer (1-H).

Step 2: Remove end cap (1-E), bumper (1-C).

Step 3: Remove spool part of (1-A) (caution, do not scratch).

Step 4: Press sleeve (1-A) from body (1-B).

Step 5: Inspect O-Ring (1-G) and replace if necessary.

Step 6: Lightly lubricate O-Rings (1-G) on sleeve (1-A).

Step 7: Press sleeve (1-A) into body (1-B).

Step 8: Reassemble in reverse order.

Note: Sleeve and spool (1-A) set is match ground to a specified clearance sleeve and spools (1-A) cannot be interchanged.

Air Valve Assembly Parts List

Item	Part Number	Description	Qty
⚠ 1	031-146-000	Air Valve Assembly	1
1-A	031-143-000	Sleeve and Spool Set w/Pins	1
1-B	095-119-559	Body, Air Valve	1
1-C	132-039-551	Bumper	2
1-D	165-096-559	Cap, Muffler	1
1-E	165-156-147	Cap, End	2
1-F	530-028-550	Muffler	1
1-G	560-020-360	O-Ring	8
1-H	675-068-115	Staple	2
1-J	710-015-115	Screw, Self-Tapping	4
1-K	210-008-330	Clip, Safety	1
1-M	560-029-360	O-Ring	2

For Pumps with PTFE Coated Hardware:

1	031-146-002	Air Valve Assembly	1
1-J	710-015-308	Screw, Self Tapping	4

(includes all other items on 031-146-000 above)

For Pumps with Piped Exhaust:

⚠ 1	031-147-000	Air Valve Assembly	1
-----	-------------	--------------------	---

(includes all items on 031-146-000 minus 1-D, 1-F, & 1-J)

4: AIR END

Pilot Valve Assembly

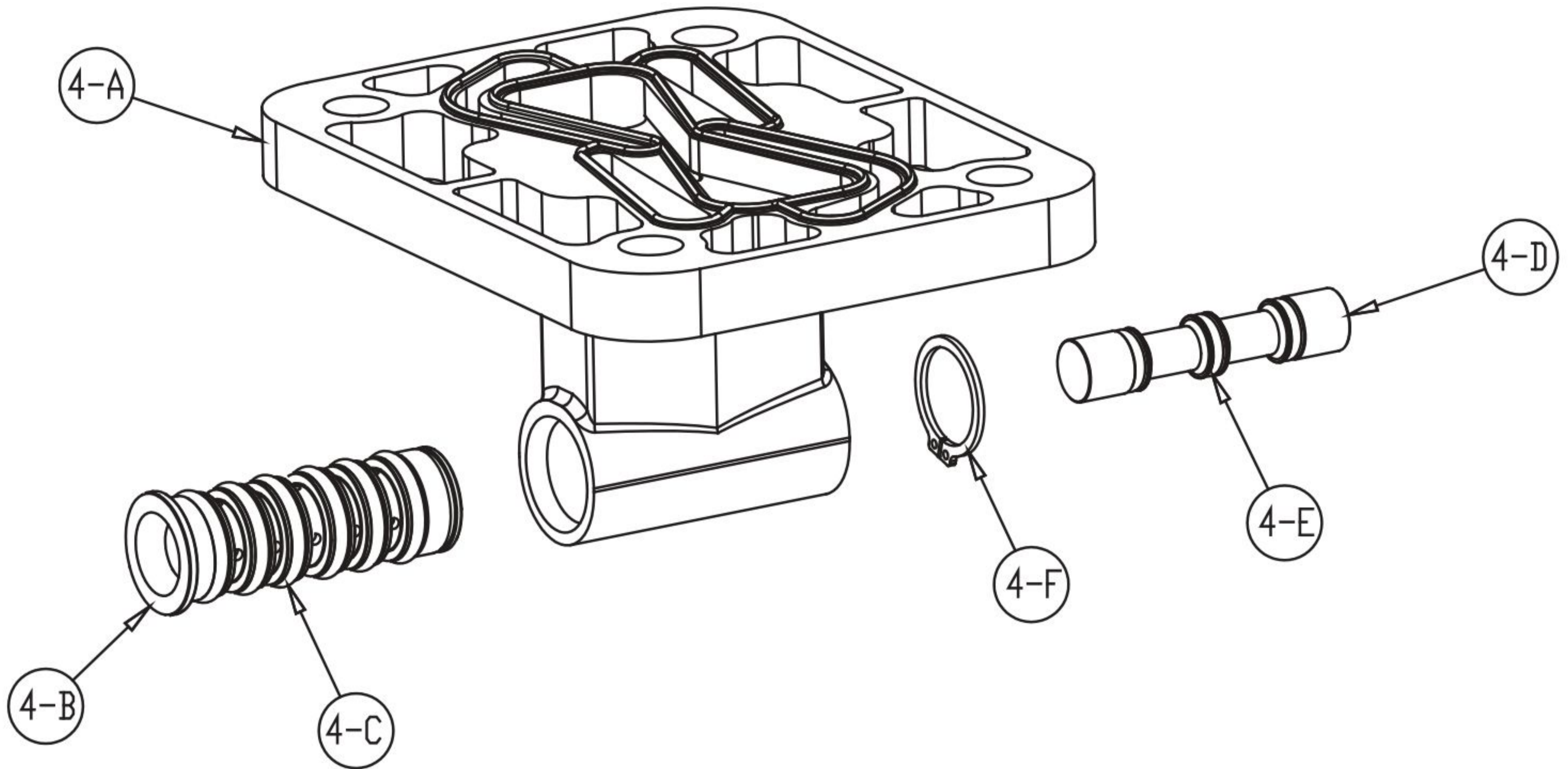

4: AIR END

Pilot Valve Servicing

With Pilot Valve removed from pump.

Step 1: Remove snap ring (4-F).

Step 2: Remove sleeve (4-B), inspect O-Rings (4-C), replace if required.

Step 3: Remove spool (4-D) from sleeve (4-B), inspect O-Rings (4E), replace if required.

Step 4: Lightly lubricate O-Rings (4-C) and (4-E).

Reassemble in reverse order.

Pilot Valve Assembly Parts List

Item	Part Number	Description	Qty
4	095.110.000	Pilot Valve Assembly	1
4-A	095.095.157	Valve Body	1
4-B	755.052.000	Sleeve (With O-Rings)	1
4-C	560.033.360	O-Ring (Sleeve)	6
4-D	775.055.000	Spool (With O-Rings)	1
4-E	560.023.360	O-Ring (Spool)	3
4-F	675.037.080	Retaining Ring	1

For Pumps with Cast Iron Center Section

Item	Part Number	Description	Qty
4	095.110.558	Pilot Valve Assembly	1
4-A	095.095.558	Valve Body	1

(includes all other items used on 095.110.000)

For Pumps with Stainless Steel Center Section

Item	Part Number	Description	Qty
4	095.110.110	Pilot Valve Assembly	1
4-A	095.095.110	Valve Body	1

(includes all other items used on 095.110.000)

Intermediate Assembly Drawing

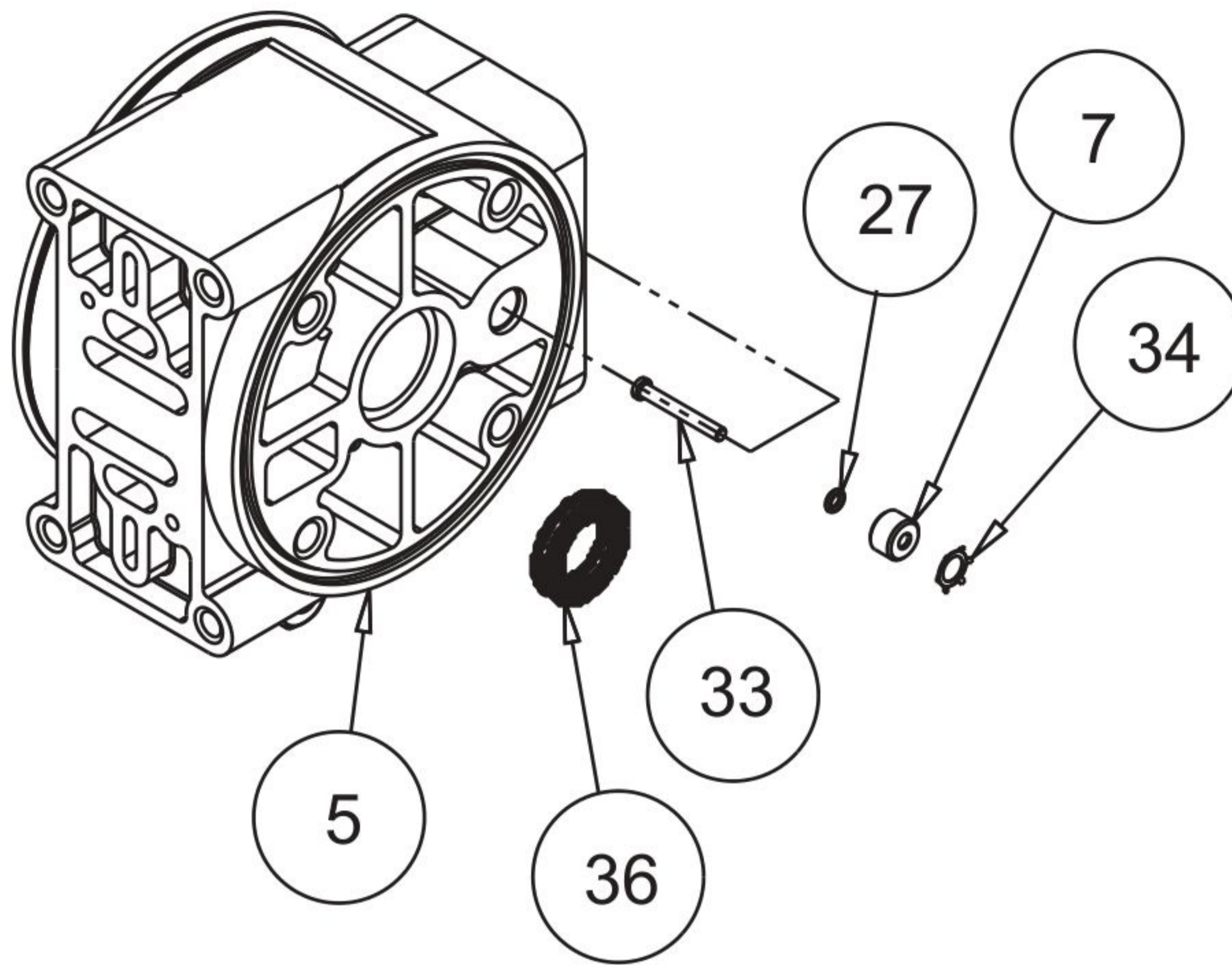

Intermediate Assembly Drawing

Step 1: Remove plunger, actuator (33) from center of intermediate pilot valve cavity.

Step 2: Remove Ring, Retaining (34), discard.

Step 3: Remove bushing, plunger (7), inspect for wear and replace if necessary with genuine parts.

Step 4: Remove O-Ring (27), inspect for wear and replace if necessary with genuine parts.

Step 5: Lightly lubricate O-Ring (27) and insert into intermediate.

Step 6: Reassemble in reverse order.

Step 7: Remove Seal, Diaphragm Rod (36).

Step 8: Clean seal area, lightly lubricate and install new Seal, Diaphragm Rod (36).

Intermediate Repair Parts List

Item	Part Number	Description	Qty
5	114.024.157	Bracket, Intermediate	1
	114.024.010	Bracket, Intermediate	1
	114.024.110	Bracket, Intermediate	1
7	135.034.506	Bushing, Plunger	2
27	560.001.360	O-Ring	2
33	620.020.115	Plunger, Actuator	2
34	675.042.115	Ring, Retaining*	2
36	720.004.360	Seal, Diaphragm Rod	2

***Note:** It is recommended that when plunger components are serviced, new retaining rings be installed.

⚠ IMPORTANT



When the pumped product source is at a higher level than the pump (flooded suction condition), pipe the exhaust higher than the product source to prevent siphoning spills. In the event of a diaphragm failure a complete rebuild of the center section is recommended.

Diaphragm Service Drawing, with Overlay

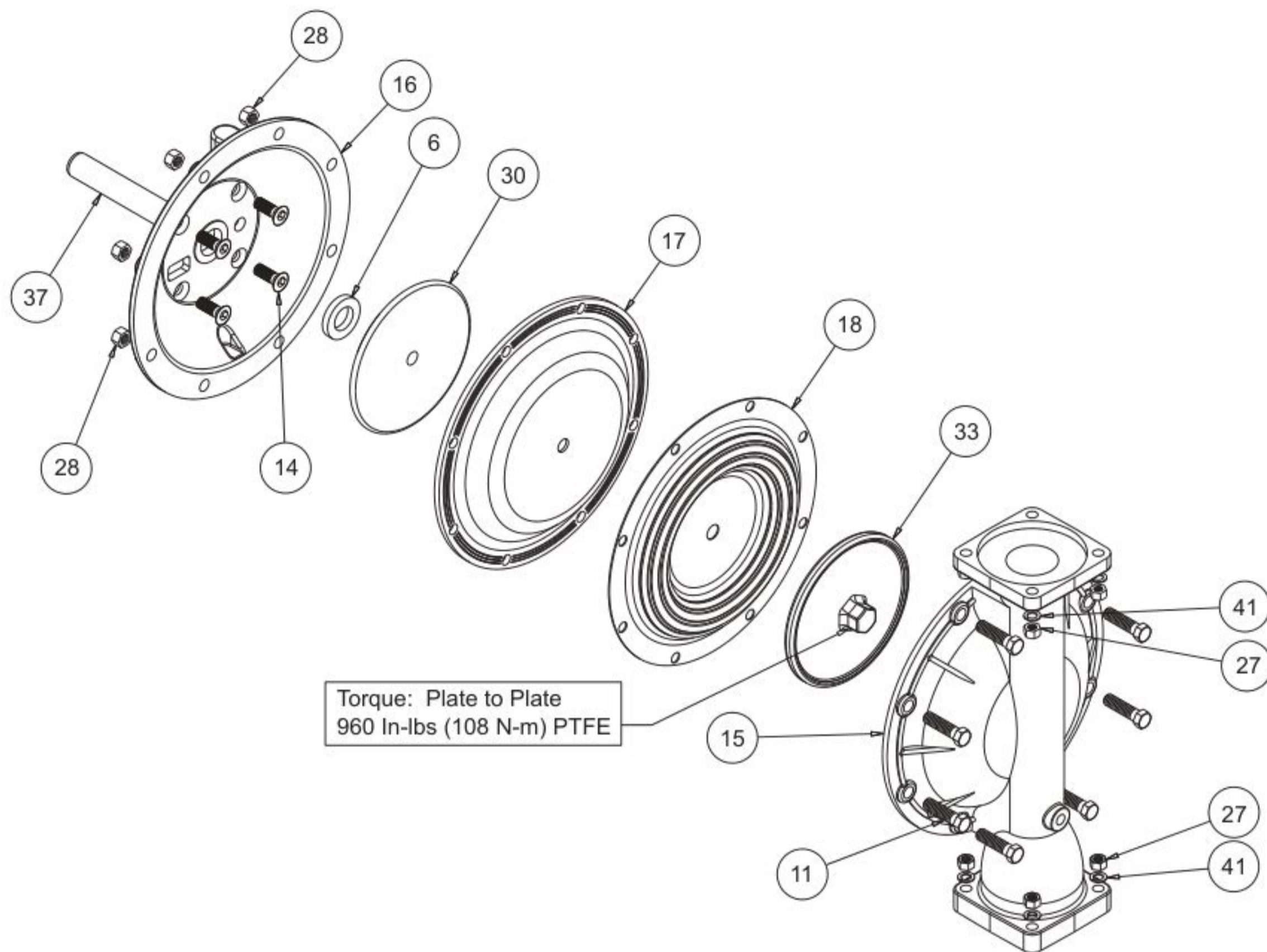

Diaphragm Service Drawing, Non-Overlay

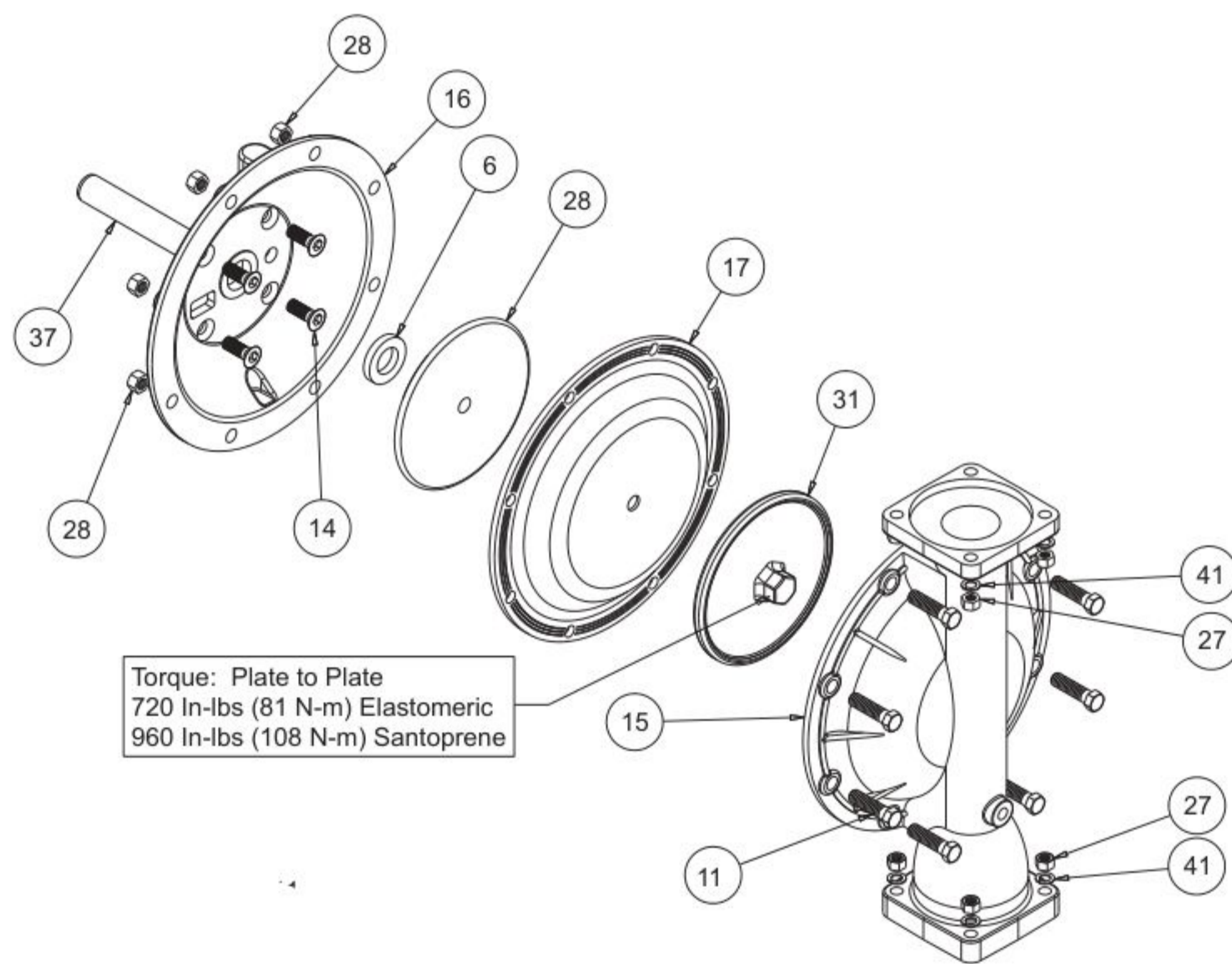

One-Piece Bonded *Diaphragm Service Drawing

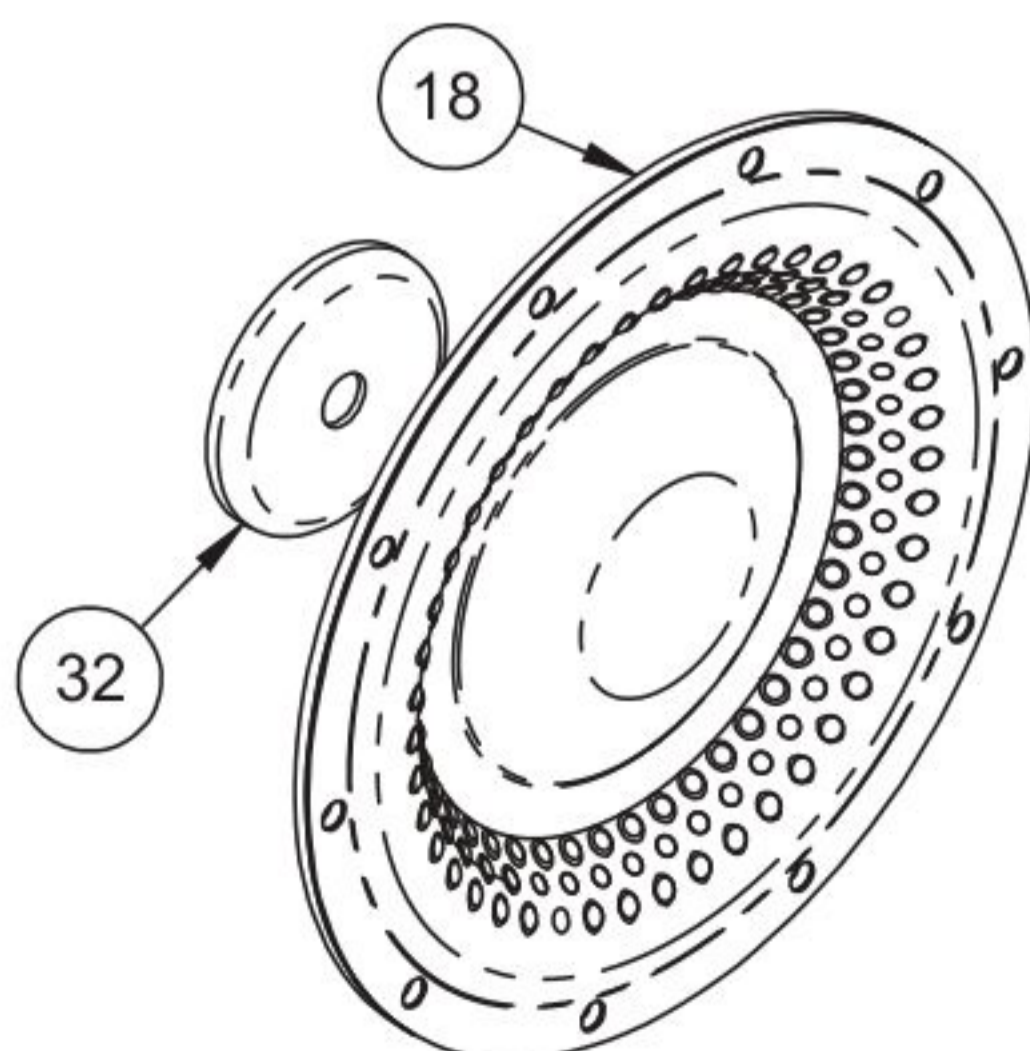

***AVAILABLE FOR FIELD CONVERSION FROM OVERLAY TO ONE-PIECE BONDED DIAPHRAGM KITS:**

Kit:	475-253-000	
2	286-118-000	One-Piece Diaphragm
2	612-214-150	Inner Plates

5: WET END

Diaphragm Servicing

Step 1: With manifolds and outer chambers removed, remove diaphragm assemblies from diaphragm rod. **DO NOT** use a pipe wrench or similar tool to remove assembly from rod. Flaws in the rod surface may damage bearings and seal. Soft jaws in a vise are recommended to prevent diaphragm rod damage.

Step 1.A: NOTE: Not all inner diaphragm plates are threaded. Some models utilize a through hole in the inner diaphragm plate. If required to separate diaphragm assembly, place assembly in a vise, gripping on the exterior cast diameter of the inner plate. Turn the outer plate clockwise to separate the assembly.

Always inspect diaphragms for wear cracks or chemical attack. Inspect inner and outer plates for deformities, rust scale and wear. Inspect intermediate bearings for elongation and wear. Inspect diaphragm rod for wear or marks.

Clean or repair if appropriate. Replace as required.

Step 2: Reassembly: There are two different types of diaphragm plate assemblies utilized throughout the F T A product line: Outer plate with a threaded stud, diaphragm, and a threaded inner plate.

Outer plate with a threaded stud, diaphragm, and an inner plate with through hole. Secure threaded inner plate in a vise. Ensure that the plates are being installed with the outer radius against the diaphragm.

Step 3: Lightly lubricate, with a compatible material, the inner faces of both outer and inner diaphragm plates when using on non Overlay diaphragms (For EPDM water is recommended). No lubrication is required.

Step 4: Push the threaded outer diaphragm plate through the center hole of the diaphragm. **Note:** Most diaphragms are installed with the natural bulge out towards the fluid side. F05, F07, and F10 non-metallic units are installed with the natural bulge in towards the air side.

Step 5: Thread or place, outer plate stud into the inner plate. For threaded inner plates, use a torque wrench to tighten the assembly together. Torque values are called out on the exploded view.

Repeat procedure for second side assembly. Allow a minimum of 15 minutes to elapse after torquing, then re-torque the assembly to compensate for stress relaxation in the clamped assembly.

Step 6: Thread one assembly onto the diaphragm rod with sealing washer (when used) and bumper.

Step 7: Install diaphragm rod assembly into pump and secure by installing the outer chamber in place and tightening the capscrews.

Step 8: On opposite side of pump, thread the remaining assembly onto the diaphragm rod. Using a torque wrench, tighten the assembly to the diaphragm rod. Align diaphragm through bolt holes, always going forward past the recommended torque. Torque values are called out on the exploded view. **NEVER** reverse to align holes, if alignment cannot be achieved without damage to diaphragm, loosen complete assemblies, rotate diaphragm and reassemble as described above.

Step 9: Complete assembly of entire unit. One Piece Diaphragm Servicing (Bonded PTFE with integral plate) The One Piece diaphragm has a threaded stud installed in the integral plate at the factory. The inner diaphragm plate has a through hole instead of a threaded hole. Place the inner plate over the diaphragm stud and thread the first diaphragm / inner plate onto the diaphragm rod only until the inner plate contacts the rod. Do not tighten. A small amount of grease may be applied between the inner plate and the diaphragm to facilitate assembly. Insert the diaphragm / rod assembly into the pump and install the outer chamber. Turn the pump over and thread the second diaphragm / inner plate onto the diaphragm rod. Turn the diaphragm until the inner plate contacts the rod and hand tighten the assembly. Continue tightening until the bolt holes align with the inner chamber holes. **DO NOT LEAVE THE ASSEMBLY LOOSE.**

IMPORTANT



Read these instructions completely, before installation and start-up. It is the responsibility of the purchaser to retain this manual for reference. Failure to comply with the recommendations stated in this manual will damage the pump, and void factory warranty.

Solenoid Shifted Air Valve

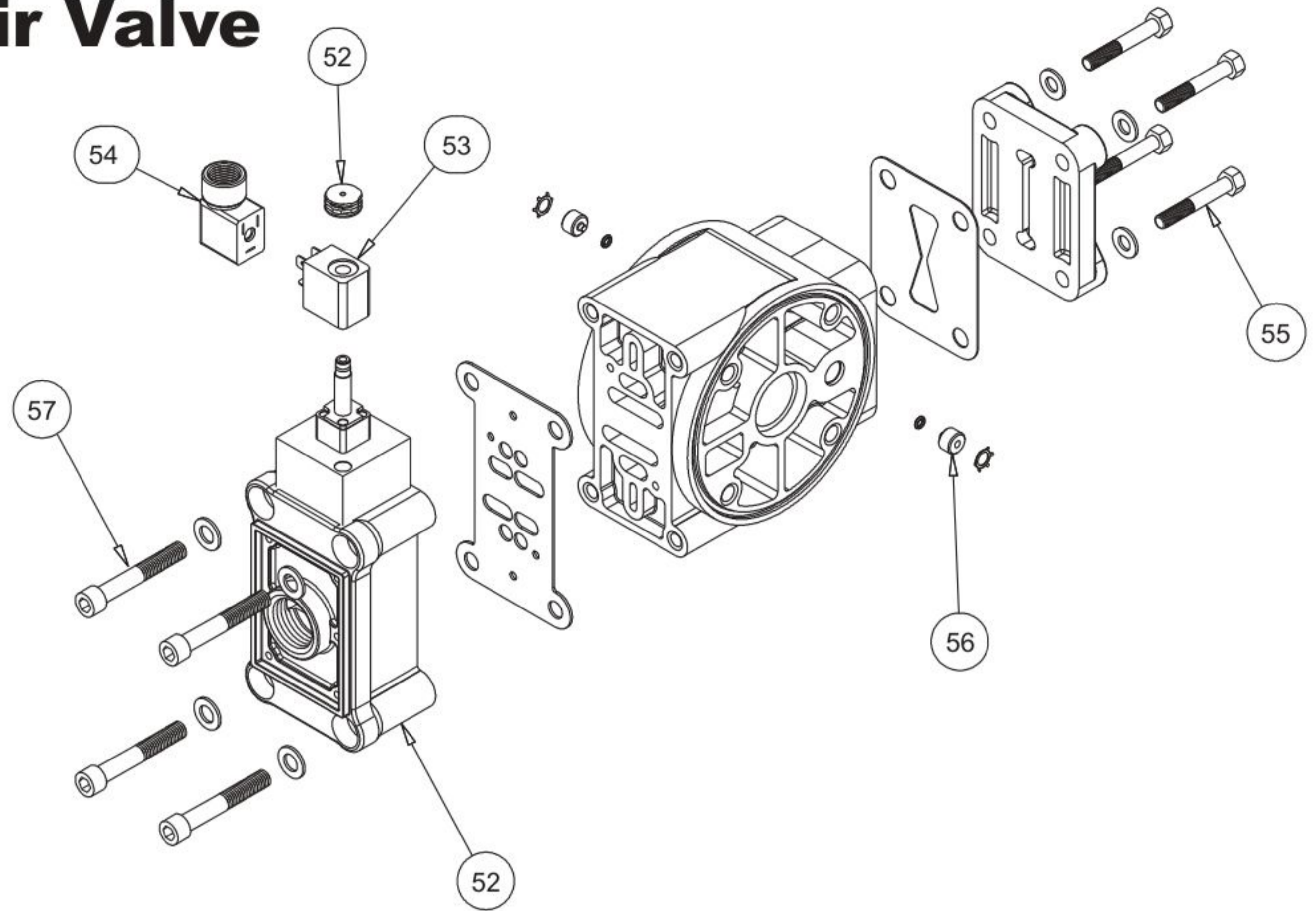
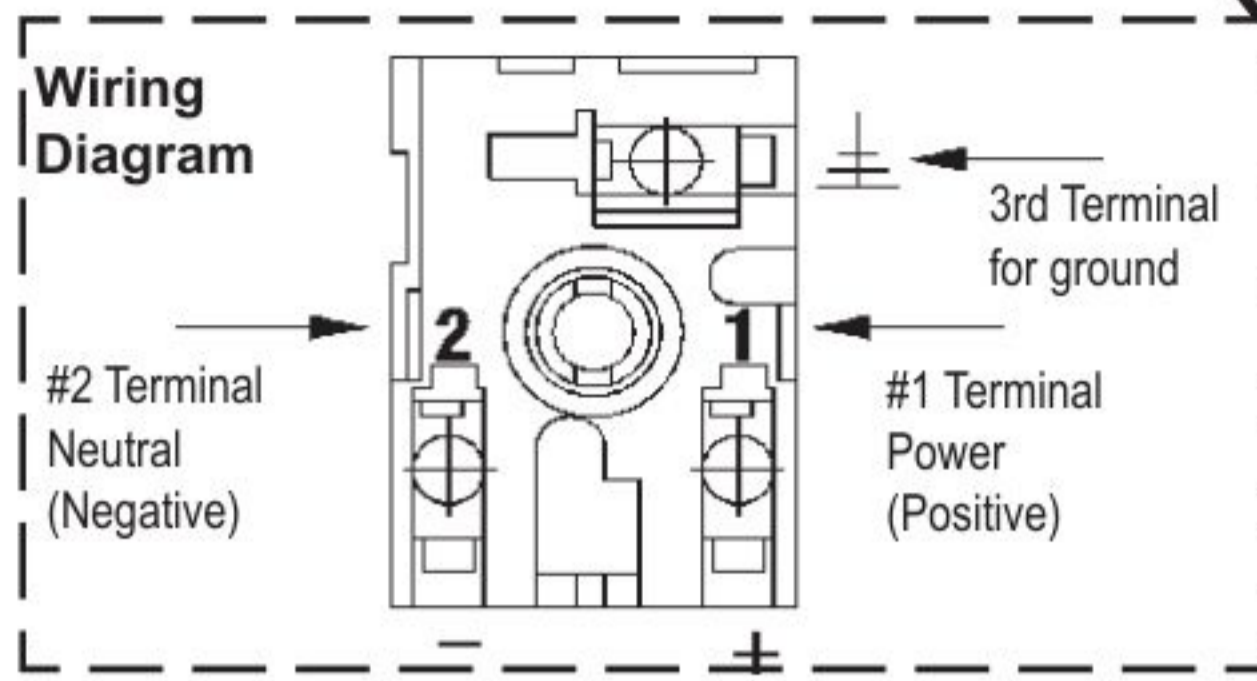

Solenoid Shifted Air Valve Parts List

(Includes All Items Used on Composite Repair Parts List Except as Shown)

Item	Part Number	Description	Qty
52	893.097.000	Solenoid Valve, NEMA4	1
53	219.001.000	Solenoid Coil, 24VDC	1
	219.004.000	Solenoid Coil, 24VAC/12VDC	1
	219.002.000	Solenoid Coil, 120VAC	1
	219.003.000	Solenoid Coil, 240VAC	1
54	241.001.000	Connector, conduit	1
55	170.045.115	Capscrew, Hex HD 5/16-18 x 1.25	4
56	618.051.150	Plug	2
57	171.053.115	Capscrew, Socket Head	4

Solenoid Shifted Operation

The Solenoid Shifted pump has a solenoid operated, air distribution valve in place of the standard pilot operated, air distribution valve. Where a pilot valve is normally utilized to cycle the pump's air distribution valve, an electric solenoid is utilized. The solenoid coil is connected to a customer-supplied control. As the solenoid is powered, one of the pump's air chambers is pressurized while the other chamber is exhausted. When electric power is turned off, the solenoid shifts and the pressurized chamber is exhausted while the other chamber is pressurized. By alternately applying and removing power to the solenoid, the pump cycles much like a standard pump, with one exception. This option provides a way to precisely control and monitor pump speed.

Before Installation

BEFORE WIRING THE SOLENOID, make certain it is compatible with your system voltage.

▲ For Explosion Proof Solenoid Coils used in North America and outside the European Union.

52	219.009.001	Solenoid Coil, 120VAC 60 Hz	1
	219.009.002	Solenoid Coil, 240VAC 60 Hz	1
	219.009.003	Solenoid Coil, 12VDC	1
	219.009.004	Solenoid Coil, 24VDC	1
	219.009.005	Solenoid Coil, 110VAC 50 Hz	1
	219.009.006	Solenoid Coil, 230VAC 50 Hz	1

Note: Item 53 (Conduit Connector) is not required

*Special Conditions For Safe Use

A fuse corresponding to its rated current (max. $3 \cdot I_{rat}$ according IEC 60127-2-1) or a motor protecting switch with short-circuit and thermal instantaneous tripping (set to rated current) shall be connected in series to each solenoid as short circuit protection. For very low rated currents of the solenoid the fuse of lowest current value according to the indicated IEC standard will be sufficient. The fuse may be accommodated in the associated supply unit or shall be separately arranged. The rated voltage to the fuse shall be equal to or greater than the stated rated voltage of the magnet coil. The breakage capacity of the fuse-link shall be as high as or higher than the maximum expected short circuit current at the location of the installation (usually 1500 A). A maximum permissible ripple of 20% is valid for all magnets of direct-current design.

For ATEX Compliant Solenoid Coils used in the European Union

52	219.011.001	Solenoid Coil, Single mounting 12 VDC, 3.3W / 267mA	1
	219.011.002	Solenoid Coil, Single mounting 24 VDC, 3.3W / 136mA	1
	219.011.003	Solenoid Coil, Single mounting 110/120 VAC, 3.4W / 29mA	1
	219.011.004	Solenoid Coil, Single mounting 220/240 VAC, 3.4W / 15mA	1

Note: Item 37 (Conduit Connector) is not required

Compressed Air Temperature Range: Maximum Ambient Temperature to plus 50°C